

# FRAISE-DE-FINITION-MD-E2+-EZI-ALPHA · FINISHING- ENDMILL-SC-E2+-EZI-ALPHA · SCHLICHTFRÄSER-HM-E2- +-EZI-ALPHA



SWISS MADE

21144A-10

Version vom 07.05.2026

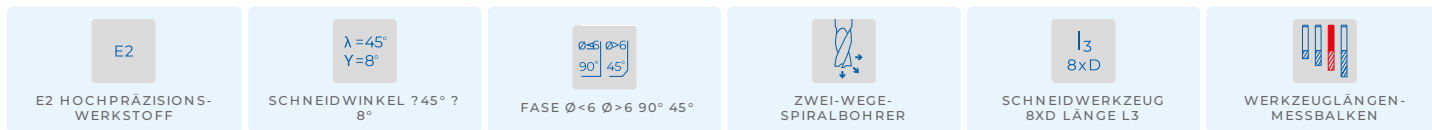

## WERKSTOFFKOMPATIBILITÄT

●●● Ausgezeichnet (3/3) ●●○ Gut (2/3) ●○○ Möglich (1/3) ○○○ Nicht empfohlen

WERKSTOFF	SPEZIFIKATION	GRP	21144A-10
<b>Legierte und unlegierte Stähle</b> Unlegierte Stähle	Rm < 450 N/mm <sup>2</sup>	1a	●●●
	Rm 450–700 N/mm <sup>2</sup>	1b	●●●
	Rm 700–900 N/mm <sup>2</sup>	1c	●●●
	Rm > 1200 N/mm <sup>2</sup>	1d	●●●
<b>Rostfreie Stähle</b> Rostfreie Stähle	Rm < 650 N/mm <sup>2</sup>	2a	●●●
	Rm 650–950 N/mm <sup>2</sup>	2b	●●●
	Rm > 950 N/mm <sup>2</sup>	2c	●●●
<b>Gehärtete Stähle</b> Gehärtete Stähle	44–56 HRC	3a	●●○
	57–67 HRC	3b	●○○
<b>Exotische Werkstoffe</b> Speziallegierungen	< 32 HRC	4a	●●●
	> 32 HRC	4b	●●○
<b>Graphit</b> Industriegraphit		5	●●○
<b>Gusseisen</b> Grau- / Kugelgraphitguss	< 32 HRC	6a	●●●
	> 32 HRC	6b	●●●
<b>Titan</b> Titanlegierungen	Rm < 600 N/mm <sup>2</sup>	7a	●●●
	600 < Rm N/mm <sup>2</sup>	7b	●●●
<b>Nickellegierungen</b> Inconel, Hastelloy	Rm < 1000 N/mm <sup>2</sup>	8a	●●○
	Rm > 1000 N/mm <sup>2</sup>	8b	●●○
<b>Kupfer, Messing, Bronze</b> Kupferbasis	Rm < 850 N/mm <sup>2</sup>	9a	●○○
	Rm > 850 N/mm <sup>2</sup>	9b	●○○
<b>Aluminium</b> Aluminiumlegierungen	Si < 0.5%	10a	●○○
	0.5% < Si < 5%	10b	●○○
	Si > 5%	10c	●●○
<b>Kunststoffe</b> Technische Kunststoffe	Thermoplast	11a	●○○
	Duroplast	11b	●○○
<b>Verbundwerkstoffe</b> Faserverbundwerkstoffe	Glasfaser / GFK	12a	●○○
	Kohlefaser / KFK	12b	●○○
<b>Edelmetalle</b> Gold, Platin, Silber	Gold	13a	●○○
	Platin	13b	●○○

## TECHNISCHE ZEICHNUNG

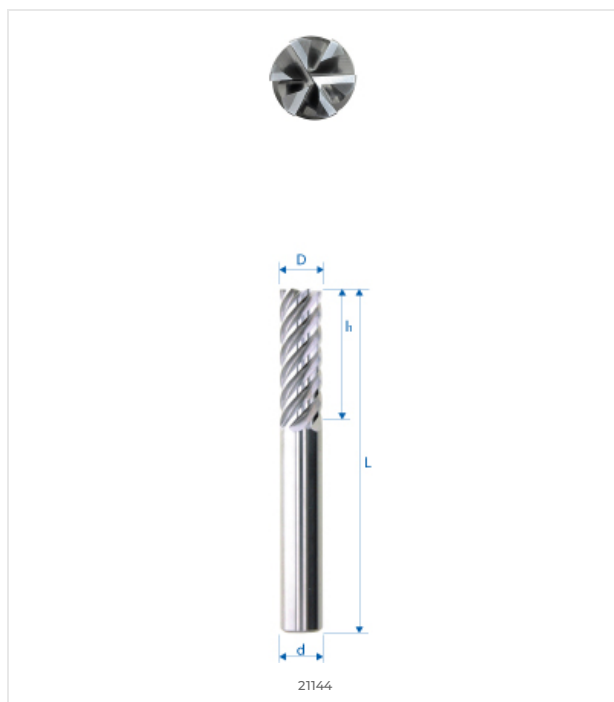

## ABMESSUNGEN

NENNMASSE	
D (0 / -0.01)	10 mm
d (h5)	10 mm
L	72 mm
l1	28 mm
l3	–
d3	–
R	–
e	–
Z	6
Fase K	0.1
w° collision	–



E-SHOP / EZI CUT  
[eskenazi.ch/eshop/21144A-10](https://eskenazi.ch/eshop/21144A-10)

© 2026 Eskenazi SA — Carouge, Genève  
Alle Rechte vorbehalten