

FRAISE-TORIQUE-MD-E2+-EZI-ALPHA+L3-POUR-MATÉRIAUX-DIFFICILES · TORIC-ENDMILL-SC-E2+-EZI-ALPHA-FOR-DIFFICULT-MATERIALS · TORISCHE-FRÄSER-HM-E2+-EZI-ALPHA-FÜR-HARTE-WERKSTOFFE

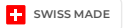

21173A-12-R2

Version vom 06.05.2026

| | | | | | | | |
|---|--|---------------------------------|----------------------------|---|--|---|--------------------------------------|
| E2 HOCHPRÄZISIONS- WERKSTOFF | $\lambda = 50^\circ$ $\gamma = -12^\circ$ SCHNEIDWINKEL 7.50° ?-12° | U-FÖRMIGE NUT WERKZEUGPROFIL | ZWEI-WEGE- SPIRALBOHRER | l_1 1.5xD 1.5XD TIEFE PRÄZISIONSWERKZEUG | l_3 DREIPUNKT- KONTAKTWERKZEUG | STANDARD- WERKZEUGVERSCHLEISSANZEIGE | SYMBOL FÜR EINSTELLBARE WINKEL |
|---|--|---------------------------------|----------------------------|---|--|---|--------------------------------------|

WERKSTOFFKOMPATIBILITÄT

●●● Ausgezeichnet (3/3) ●●○ Gut (2/3) ●○○ Möglich (1/3) ○○○ Nicht empfohlen

| WERKSTOFF | SPEZIFIKATION | GRP | 21173A-12-R2 |
|---|------------------------------|-----|--------------|
| Legierte und unlegierte Stähle <small>Unlegierte Stähle</small> | Rm < 450 N/mm ² | 1a | ●○○ |
| | Rm 450-700 N/mm ² | 1b | ●○○ |
| | Rm 700-900 N/mm ² | 1c | ●○○ |
| | Rm > 1200 N/mm ² | 1d | ●●● |
| Rostfreie Stähle <small>Rostfreie Stähle</small> | Rm < 650 N/mm ² | 2a | ●○○ |
| | Rm 650-950 N/mm ² | 2b | ●○○ |
| | Rm > 950 N/mm ² | 2c | ●●○ |
| Gehärtete Stähle <small>Gehärtete Stähle</small> | 44-56 HRC | 3a | ●●● |
| | 57-67 HRC | 3b | ●●○ |
| Exotische Werkstoffe <small>Speziallegierungen</small> | < 32 HRC | 4a | ●●● |
| | > 32 HRC | 4b | ●●● |
| Graphit <small>Industriegraphit</small> | | 5 | ○○○ |
| Gusseisen <small>Grau- / Kugelgraphitguss</small> | < 32 HRC | 6a | ●○○ |
| | > 32 HRC | 6b | ●○○ |
| Titan <small>Titanlegierungen</small> | Rm < 600 N/mm ² | 7a | ●○○ |
| | 600 < Rm N/mm ² | 7b | ●○○ |
| Nickellegierungen <small>Inconel, Hastelloy</small> | Rm < 1000 N/mm ² | 8a | ●●● |
| | Rm > 1000 N/mm ² | 8b | ●●● |
| Kupfer, Messing, Bronze <small>Kupferbasis</small> | Rm < 850 N/mm ² | 9a | ○○○ |
| | Rm > 850 N/mm ² | 9b | ○○○ |
| Aluminium <small>Aluminiumlegierungen</small> | Si < 0.5% | 10a | ○○○ |
| | 0.5% < Si < 5% | 10b | ○○○ |
| | Si > 5% | 10c | ○○○ |
| Kunststoffe <small>Technische Kunststoffe</small> | Thermoplast | 11a | ○○○ |
| | Duroplast | 11b | ○○○ |
| Verbundwerkstoffe <small>Faserverbundwerkstoffe</small> | Glasfaser / GFK | 12a | ○○○ |
| | Kohlefaser / KFK | 12b | ○○○ |
| Edelmetalle <small>Gold, Platin, Silber</small> | Gold | 13a | ○○○ |
| | Platin | 13b | ○○○ |

TECHNISCHE ZEICHNUNG

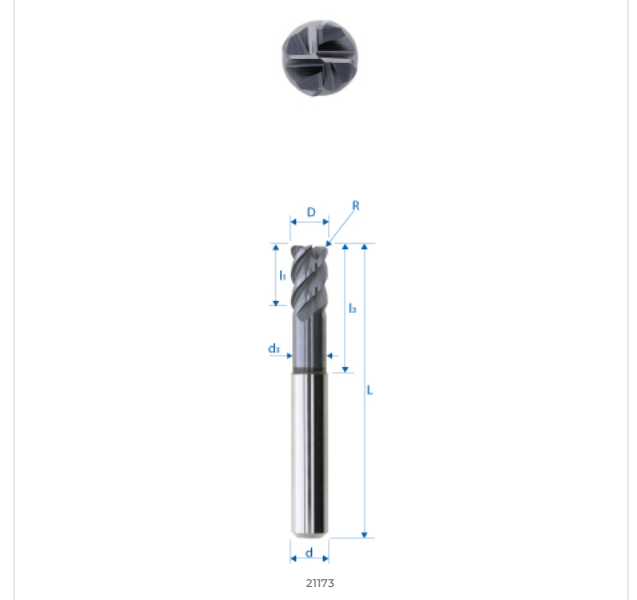

ABMESSUNGEN

| NENNMASS | |
|---------------|-------|
| D (0 / -0.01) | 12 mm |
| d (h5) | 12 mm |
| L | 83 mm |
| l1 | 18 mm |
| l3 | 37 mm |
| d3 | - |
| R | 2 mm |
| e | - |
| Z | 4 |
| Fase K | - |
| w° collision | - |



E-SHOP / EZI CUT
eskenazi.ch/eshop/21173A-12-R2

© 2026 Eskenazi SA — Carouge, Genève
Alle Rechte vorbehalten