

FRAISE-À-CHANFREINER-45°-MD-E25UF-+-EZI-ALPHA ·  
 BEVEL-MILLING-CUTTER-45°-SC-E2-+-EZI-ALPHA ·  
 FASENFRÄSER-45°-HM-E25UF-+-EZI-ALPHA



SWISS MADE

21730A-0.6

Version vom 07.05.2026

E2

E2 HOCHPRÄZISIONS-WERKSTOFF

$\lambda = 0^\circ$   
 $\gamma = 8^\circ$

WERKZEUGWINKEL LAMBDA 0°  
GAMMA 8°



V-NUT FASENWERKZEUG FORM



SEITLICH SCHNEIDENDER  
SPIRALBOHRER

WERKSTOFFKOMPATIBILITÄT

●●● Ausgezeichnet (3/3) ●●○ Gut (2/3) ●○○ Möglich (1/3) ○○○ Nicht empfohlen

WERKSTOFF	SPEZIFIKATION	GRP	21730A-0.6
<b>Legierte und unlegierte Stähle</b> Unlegierte Stähle	Rm < 450 N/mm <sup>2</sup>	1a	●●●
	Rm 450–700 N/mm <sup>2</sup>	1b	●●●
	Rm 700–900 N/mm <sup>2</sup>	1c	●●●
	Rm > 1200 N/mm <sup>2</sup>	1d	●●●
<b>Rostfreie Stähle</b> Rostfreie Stähle	Rm < 650 N/mm <sup>2</sup>	2a	●●●
	Rm 650–950 N/mm <sup>2</sup>	2b	●●●
	Rm > 950 N/mm <sup>2</sup>	2c	●●●
<b>Gehärtete Stähle</b> Gehärtete Stähle	44–56 HRC	3a	●●○
	57–67 HRC	3b	●○○
<b>Exotische Werkstoffe</b> Speziallegierungen	< 32 HRC	4a	●●○
	> 32 HRC	4b	●●○
<b>Graphit</b> Industriegrphit		5	●●●
<b>Gusseisen</b> Grau- / Kugelgraphitguss	< 32 HRC	6a	●●●
	> 32 HRC	6b	●●●
<b>Titan</b> Titanlegierungen	Rm < 600 N/mm <sup>2</sup>	7a	●●●
	600 < Rm N/mm <sup>2</sup>	7b	●●●
<b>Nickellegierungen</b> Inconel, Hastelloy	Rm < 1000 N/mm <sup>2</sup>	8a	●●○
	Rm > 1000 N/mm <sup>2</sup>	8b	●●○
<b>Kupfer, Messing, Bronze</b> Kupferbasis	Rm < 850 N/mm <sup>2</sup>	9a	●●○
	Rm > 850 N/mm <sup>2</sup>	9b	●●○
<b>Aluminium</b> Aluminiumlegierungen	Si < 0.5%	10a	●●○
	0.5% < Si < 5%	10b	●●○
	Si > 5%	10c	●●●
<b>Kunststoffe</b> Technische Kunststoffe	Thermoplast	11a	●○○
	Duroplast	11b	●○○
<b>Verbundwerkstoffe</b> Faserverbundwerkstoffe	Glasfaser / GFK	12a	●●●
	Kohlefaser / KFK	12b	●●●
<b>Edelmetalle</b> Gold, Platin, Silber	Gold	13a	●●○
	Platin	13b	●●○

TECHNISCHE ZEICHNUNG

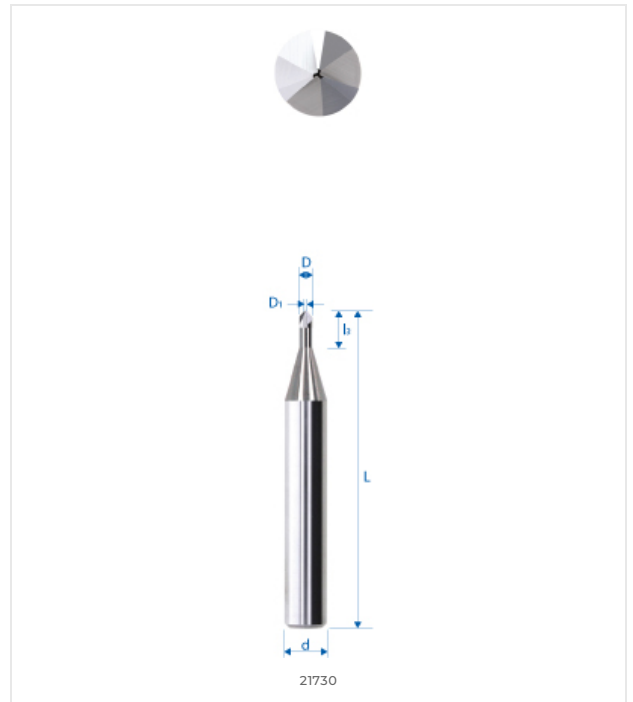

ABMESSUNGEN

NENNMASSE	
D (0 / -0.01)	0.6 mm
d (h5)	3 mm
L	38 mm
l1	0.25 mm
l3	2 mm
d3	–
R	–
e	0.1 mm
Z	3
Fase K	–
w° collision	9.8°



E-SHOP / EZI CUT  
[eskenazi.ch/eshop/21730A-0.6](https://eskenazi.ch/eshop/21730A-0.6)