

FRAISE-A-CHANFREINER-BI-FACE-90°-Z:3-MD-E25-UF-+-EZI-ALPHA-3 · BEVEL-MILLING-CUTTER-BI-FACE-90°-Z:3-CARBIDE-E25-UF-+-EZI-ALPHA-3 · FASENFRAESER-BI-FACE-90°-Z:3-HM-E25-UF-+-EZI-ALPHA-3



SWISS MADE

21735A-2

Version vom 22.06.2026

E2

E2 HOCHPRÄZISIONS-WERKSTOFF

$\lambda = 0^\circ$
 $\gamma = 8^\circ$

WERKZEUGWINKEL LAMBDA 0°
GAMMA 8°



BIFACE MEHRPUNKT-SCHNITTSTELLE



SEITLICH SCHNEIDENDER SPIRALBOHRER

WERKSTOFFKOMPATIBILITÄT

●●● Ausgezeichnet (3/3) ●●○ Gut (2/3) ●○○ Möglich (1/3) ○○○ Nicht empfohlen

| WERKSTOFF | SPEZIFIKATION | GRP | 21735A-2 |
|---|------------------------------|-----|----------|
| Legierte und unlegierte Stähle <small>Unlegierte Stähle</small> | Rm < 450 N/mm ² | 1a | ●●● |
| | Rm 450–700 N/mm ² | 1b | ●●● |
| | Rm 700–900 N/mm ² | 1c | ●●● |
| | Rm > 1200 N/mm ² | 1d | ●●● |
| Rostfreie Stähle <small>Rostfreie Stähle</small> | Rm < 650 N/mm ² | 2a | ●●● |
| | Rm 650–950 N/mm ² | 2b | ●●● |
| | Rm > 950 N/mm ² | 2c | ●●● |
| Gehärtete Stähle <small>Gehärtete Stähle</small> | 44–56 HRC | 3a | ●●○ |
| | 57–67 HRC | 3b | ●○○ |
| Exotische Werkstoffe <small>Speziallegierungen</small> | < 32 HRC | 4a | ●●○ |
| | > 32 HRC | 4b | ●●○ |
| Graphit <small>Industriegraphit</small> | | 5 | ●●● |
| Gusseisen <small>Grau- / Kugelgraphitguss</small> | < 32 HRC | 6a | ●●● |
| | > 32 HRC | 6b | ●●● |
| Titan <small>Titanlegierungen</small> | Rm < 600 N/mm ² | 7a | ●●● |
| | 600 < Rm N/mm ² | 7b | ●●● |
| Nickellegierungen <small>Inconel, Hastelloy</small> | Rm < 1000 N/mm ² | 8a | ●●○ |
| | Rm > 1000 N/mm ² | 8b | ●●○ |
| Kupfer, Messing, Bronze <small>Kupferbasis</small> | Rm < 850 N/mm ² | 9a | ●●○ |
| | Rm > 850 N/mm ² | 9b | ●●○ |
| Aluminium <small>Aluminiumlegierungen</small> | Si < 0.5% | 10a | ●●○ |
| | 0.5% < Si < 5% | 10b | ●●○ |
| | Si > 5% | 10c | ●●● |
| Kunststoffe <small>Technische Kunststoffe</small> | Thermoplast | 11a | ●○○ |
| | Duroplast | 11b | ●○○ |
| Verbundwerkstoffe <small>Faserverbundwerkstoffe</small> | Glasfaser / GFK | 12a | ●●● |
| | Kohlefaser / KFK | 12b | ●●● |
| Edelmetalle <small>Gold, Platin, Silber</small> | Gold | 13a | ●●○ |
| | Platin | 13b | ●●○ |

TECHNISCHE ZEICHNUNG

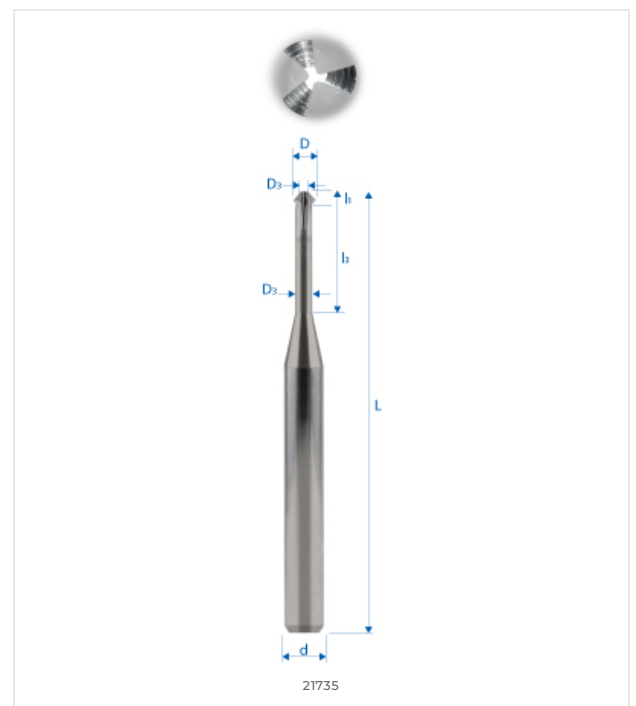

ABMESSUNGEN

| NENNMASSE | |
|---------------|--------|
| D (0 / -0.01) | 2 mm |
| d (h5) | 3 mm |
| L | 50 mm |
| l1 | 0.5 mm |
| l3 | 6 mm |
| d3 | – |
| R | – |
| e | – |
| Z | 3 |
| Fase K | – |
| w° collision | 3.7° |



E-SHOP / EZI CUT
eskenazi.ch/eshop/21735A-2

© 2026 Eskenazi SA — Carouge, Genève
Alle Rechte vorbehalten