

# FRAISE-1/4-DE-CERCLE-CONCAVE-MD-E2-+-EZI-ALPHA · FORM-RELIEVED-CORNER-ROUDING-TOOL-SC-E2-+-EZI- ALPHA · KONKAV-VIERTELKREISFRÄSER-HM-E2-+-EZI- ALPHA



SWISS MADE

21740A-6-R1

Version vom 10.06.2026

E2

E2 HOCHPRÄZISIONS-WERKSTOFF

$\lambda = 0^\circ$   
 $\gamma = 10^\circ$

WERKZEUG LAMBDA WINKEL  $0^\circ$   
GAMMA  $10^\circ$



KONKAVES U-NUT FRÄSWERKZEUG



SEITLICH SCHNEIDENDER  
SPIRALBOHRER

## WERKSTOFFKOMPATIBILITÄT

●●● Ausgezeichnet (3/3) ●●○ Gut (2/3) ●○○ Möglich (1/3) ○○○ Nicht empfohlen

WERKSTOFF	SPEZIFIKATION	GRP	21740A-6-R1
<b>Legierte und unlegierte Stähle</b> <small>Unlegierte Stähle</small>	Rm < 450 N/mm <sup>2</sup>	1a	●●●
	Rm 450–700 N/mm <sup>2</sup>	1b	●●●
	Rm 700–900 N/mm <sup>2</sup>	1c	●●●
	Rm > 1200 N/mm <sup>2</sup>	1d	●●●
<b>Rostfreie Stähle</b> <small>Rostfreie Stähle</small>	Rm < 650 N/mm <sup>2</sup>	2a	●●●
	Rm 650–950 N/mm <sup>2</sup>	2b	●●●
	Rm > 950 N/mm <sup>2</sup>	2c	●●●
<b>Gehärtete Stähle</b> <small>Gehärtete Stähle</small>	44–56 HRC	3a	●●○
	57–67 HRC	3b	●○○
<b>Exotische Werkstoffe</b> <small>Speziallegierungen</small>	< 32 HRC	4a	●●○
	> 32 HRC	4b	●●○
<b>Graphit</b> <small>Industriegraphit</small>		5	●●●
<b>Gusseisen</b> <small>Grau- / Kugelgraphitguss</small>	< 32 HRC	6a	●●●
	> 32 HRC	6b	●●●
<b>Titan</b> <small>Titanlegierungen</small>	Rm < 600 N/mm <sup>2</sup>	7a	●●●
	600 < Rm N/mm <sup>2</sup>	7b	●●●
<b>Nickellegierungen</b> <small>Inconel, Hastelloy</small>	Rm < 1000 N/mm <sup>2</sup>	8a	●●○
	Rm > 1000 N/mm <sup>2</sup>	8b	●●○
<b>Kupfer, Messing, Bronze</b> <small>Kupferbasis</small>	Rm < 850 N/mm <sup>2</sup>	9a	●●○
	Rm > 850 N/mm <sup>2</sup>	9b	●●○
<b>Aluminium</b> <small>Aluminiumlegierungen</small>	Si < 0.5%	10a	●●○
	0.5% < Si < 5%	10b	●●○
	Si > 5%	10c	●●●
<b>Kunststoffe</b> <small>Technische Kunststoffe</small>	Thermoplast	11a	●○○
	Duroplast	11b	●○○
<b>Verbundwerkstoffe</b> <small>Faserverbundwerkstoffe</small>	Glasfaser / GFK	12a	●●●
	Kohlefaser / KFK	12b	●●●
<b>Edelmetalle</b> <small>Gold, Platin, Silber</small>	Gold	13a	●●○
	Platin	13b	●●○

## TECHNISCHE ZEICHNUNG

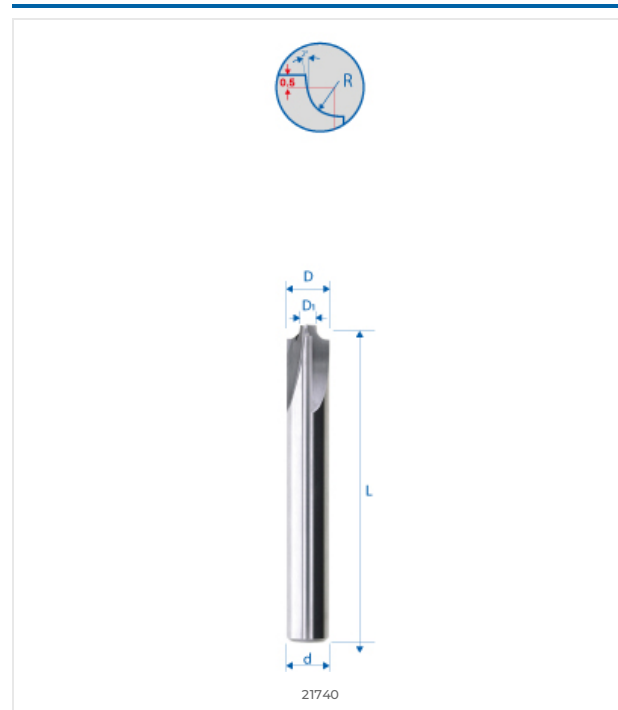

## ABMESSUNGEN

NENNMASSE	
D (0 / -0.01)	6 mm
d (h5)	6 mm
L	57 mm
l1	1 mm
l3	–
d3	–
R	–
e	3 mm
Z	4
Fase K	–
w° collision	–



E-SHOP / EZI CUT  
[eskenazi.ch/eshop/21740A-6-R1](https://eskenazi.ch/eshop/21740A-6-R1)

© 2026 Eskenazi SA — Carouge, Genève  
Alle Rechte vorbehalten