

FRAISE-D'ÉBAUCHE-MD-E2+-EZI-ALPHA+L3-POUR-ACIERS · ROUGHING-ENDMILL-SC-E2+-EZI-ALPHA+L3-FOR-STEEL · SCHAFT-SCHRUPPFRÄSER-HM-E2+-EZI-ALPHA+L3-FÜR-STAHL



SWISS MADE

22134A-10

Version vom 07.05.2026

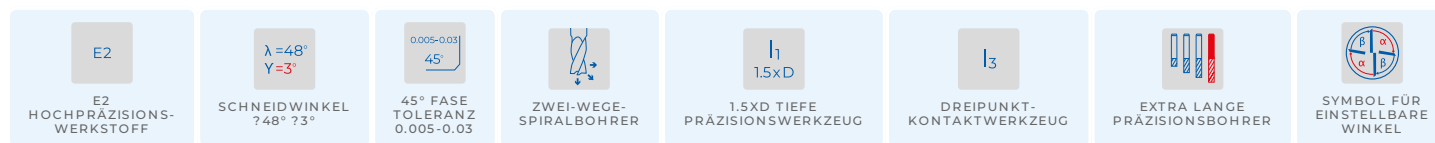

WERKSTOFFKOMPATIBILITÄT

●●● Ausgezeichnet (3/3) ●●○ Gut (2/3) ●○○ Möglich (1/3) ○○○ Nicht empfohlen

WERKSTOFF	SPEZIFIKATION	GRP	22134A-10
Legierte und unlegierte Stähle Unlegierte Stähle	Rm < 450 N/mm ²	1a	●●●
	Rm 450–700 N/mm ²	1b	●●●
	Rm 700–900 N/mm ²	1c	●●●
	Rm > 1200 N/mm ²	1d	●●●
Rostfreie Stähle Rostfreie Stähle	Rm < 650 N/mm ²	2a	●●●
	Rm 650–950 N/mm ²	2b	●●●
	Rm > 950 N/mm ²	2c	●●●
Gehärtete Stähle Gehärtete Stähle	44–56 HRC	3a	●●●
	57–67 HRC	3b	●○○
Exotische Werkstoffe Speziallegierungen	< 32 HRC	4a	●●●
	> 32 HRC	4b	●●●
Graphit Industriegrphit		5	○○○
Gusseisen Grau- / Kugelgraphitguss	< 32 HRC	6a	●●●
	> 32 HRC	6b	●●●
Titan Titanlegierungen	Rm < 600 N/mm ²	7a	●●●
	600 < Rm N/mm ²	7b	●●●
Nickellegierungen Inconel, Hastelloy	Rm < 1000 N/mm ²	8a	●●●
	Rm > 1000 N/mm ²	8b	●●●
Kupfer, Messing, Bronze Kupferbasis	Rm < 850 N/mm ²	9a	○○○
	Rm > 850 N/mm ²	9b	○○○
Aluminium Aluminiumlegierungen	Si < 0.5%	10a	○○○
	0.5% < Si < 5%	10b	○○○
	Si > 5%	10c	○○○
Kunststoffe Technische Kunststoffe	Thermoplast	11a	○○○
	Duroplast	11b	○○○
Verbundwerkstoffe Faserverbundwerkstoffe	Glasfaser / GFK	12a	○○○
	Kohlefaser / KFK	12b	○○○
Edelmetalle Gold, Platin, Silber	Gold	13a	○○○
	Platin	13b	●○○

TECHNISCHE ZEICHNUNG



ABMESSUNGEN

NENNMASSE	
D (0 / -0.01)	10 mm
d (h5)	10 mm
L	95 mm
l1	15 mm
l3	54 mm
d3	–
R	–
e	–
Z	4
Fase K	0.1
w° collision	–



E-SHOP / EZI CUT
eskenazi.ch/eshop/22134A-10