

# FRAISE-D'ÉBAUCHE-MD-E2+-EZI-ALPHA+L3-POUR-ACIERS · ROUGHING-ENDMILL-SC-E2+-EZI-ALPHA+L3-FOR-STEEL · SCHAFT-SCHRUPPFRÄSER-HM-E2+-EZI-ALPHA+L3-FÜR-STAHL



SWISS MADE

22134A-4-6

Version vom 07.05.2026

<b>E2</b> HOCHPRÄZISIONS- WERKSTOFF	$\lambda = 48^\circ$ $\gamma = 3^\circ$ SCHNEIDWINKEL 748° 73°	0.005-0.03 45° 45° FASE TOLERANZ 0.005-0.03	ZWEI-WEGE- SPIRALBOHRER	$l_h$ 1.5xD 1.5XD TIEFE PRÄZISIONSWERKZEUG	l3 DREIPUNKT- KONTAKTWERKZEUG	EXTRA LANGE PRÄZISIONSBOHRER	SYMBOL FÜR EINSTELLBARE WINKEL
---	---	---	----------------------------	---	-------------------------------------	---------------------------------	--------------------------------------

## WERKSTOFFKOMPATIBILITÄT

●●● Ausgezeichnet (3/3) ●●○ Gut (2/3) ●○○ Möglich (1/3) ○○○ Nicht empfohlen

WERKSTOFF	SPEZIFIKATION	GRP	22134A-4-6
<b>Legierte und unlegierte Stähle</b> Unlegierte Stähle	Rm < 450 N/mm <sup>2</sup>	1a	●●○
	Rm 450–700 N/mm <sup>2</sup>	1b	●●○
	Rm 700–900 N/mm <sup>2</sup>	1c	●●○
	Rm > 1200 N/mm <sup>2</sup>	1d	●●○
<b>Rostfreie Stähle</b> Rostfreie Stähle	Rm < 650 N/mm <sup>2</sup>	2a	●●○
	Rm 650–950 N/mm <sup>2</sup>	2b	●●○
	Rm > 950 N/mm <sup>2</sup>	2c	●●○
<b>Gehärtete Stähle</b> Gehärtete Stähle	44–56 HRC	3a	●●○
	57–67 HRC	3b	●○○
<b>Exotische Werkstoffe</b> Speziallegierungen	< 32 HRC	4a	●●○
	> 32 HRC	4b	●●○
<b>Graphit</b> Industriegraphit		5	○○○
<b>Gusseisen</b> Grau- / Kugelgraphitguss	< 32 HRC	6a	●●○
	> 32 HRC	6b	●●○
<b>Titan</b> Titanlegierungen	Rm < 600 N/mm <sup>2</sup>	7a	●●○
	600 < Rm N/mm <sup>2</sup>	7b	●●○
<b>Nickellegierungen</b> Inconel, Hastelloy	Rm < 1000 N/mm <sup>2</sup>	8a	●●○
	Rm > 1000 N/mm <sup>2</sup>	8b	●●○
<b>Kupfer, Messing, Bronze</b> Kupferbasis	Rm < 850 N/mm <sup>2</sup>	9a	○○○
	Rm > 850 N/mm <sup>2</sup>	9b	○○○
<b>Aluminium</b> Aluminiumlegierungen	Si < 0.5%	10a	○○○
	0.5% < Si < 5%	10b	○○○
	Si > 5%	10c	○○○
<b>Kunststoffe</b> Technische Kunststoffe	Thermoplast	11a	○○○
	Duroplast	11b	○○○
<b>Verbundwerkstoffe</b> Faserverbundwerkstoffe	Glasfaser / GFK	12a	○○○
	Kohlefaser / KFK	12b	○○○
<b>Edelmetalle</b> Gold, Platin, Silber	Gold	13a	○○○
	Platin	13b	●○○

## TECHNISCHE ZEICHNUNG

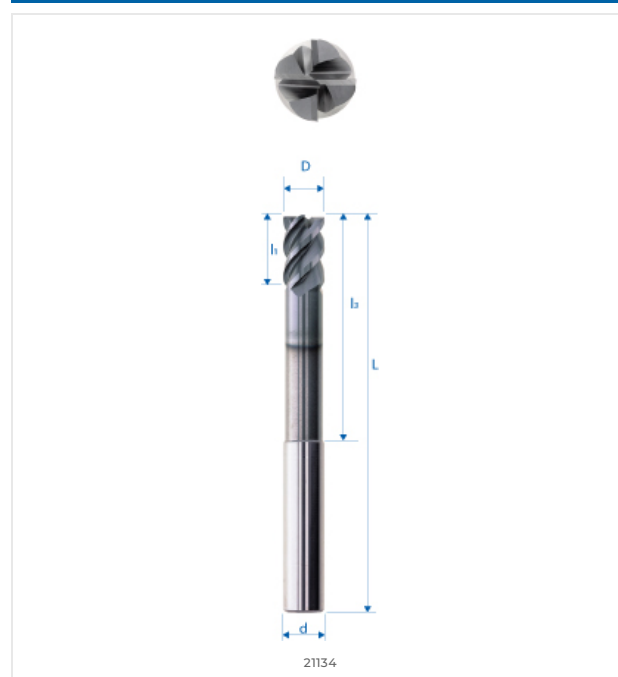

## ABMESSUNGEN

NENNMASS	
D (0 / -0.01)	4 mm
d (h5)	6 mm
L	68 mm
l <sub>l</sub>	6 mm
l <sub>3</sub>	33 mm
d <sub>3</sub>	–
R	–
e	–
Z	3
Fase K	0.1
w° collision	1.6°



E-SHOP / EZI CUT  
[eskenazi.ch/eshop/22134A-4-6](https://eskenazi.ch/eshop/22134A-4-6)