

# FRAISE-TORIQUE-MD-E2+-EZI-ALPHA+L3-POUR-MATÉRIAUX-DIFFICILES · TORIC-ENDMILL-SC-E2+-EZI-ALPHA-FOR-DIFFICULT-MATERIALS · TORISCHE-FRÄSER-HM-E2+-EZI-ALPHA-FÜR-HARTE-WERKSTOFFE



SWISS MADE

22173A-12-R2

Version vom 21.06.2026

<b>E2</b> HOCHPRÄZISIONS- WERKSTOFF	$\lambda = 50^\circ$ $\gamma = -12^\circ$ SCHNEIDWINKEL 7.50° ?-12°	U-FÖRMIGE NUT WERKZEUGPROFIL	ZWEI-WEGE- SPIRALBOHRER	$l_1$ 1.5xD 1.5XD TIEFE PRÄZISIONSWERKZEUG	$l_3$ DREIPUNKT- KONTAKTWERKZEUG	STANDARD- WERKZEUGVERSCHLEISSANZEIGE	SYMBOL FÜR EINSTELLBARE WINKEL
---	--	---------------------------------	----------------------------	---	--	---	--------------------------------------

## WERKSTOFFKOMPATIBILITÄT

●●● Ausgezeichnet (3/3) ●●○ Gut (2/3) ●○○ Möglich (1/3) ○○○ Nicht empfohlen

WERKSTOFF	SPEZIFIKATION	GRP	22173A-12-R2
<b>Legierte und unlegierte Stähle</b> <small>Unlegierte Stähle</small>	Rm < 450 N/mm <sup>2</sup>	1a	●○○
	Rm 450-700 N/mm <sup>2</sup>	1b	●○○
	Rm 700-900 N/mm <sup>2</sup>	1c	●○○
	Rm > 1200 N/mm <sup>2</sup>	1d	●●●
<b>Rostfreie Stähle</b> <small>Rostfreie Stähle</small>	Rm < 650 N/mm <sup>2</sup>	2a	●○○
	Rm 650-950 N/mm <sup>2</sup>	2b	●○○
	Rm > 950 N/mm <sup>2</sup>	2c	●●○
<b>Gehärtete Stähle</b> <small>Gehärtete Stähle</small>	44-56 HRC	3a	●●●
	57-67 HRC	3b	●●○
<b>Exotische Werkstoffe</b> <small>Speziallegierungen</small>	< 32 HRC	4a	●●●
	> 32 HRC	4b	●●●
<b>Graphit</b> <small>Industriegraphit</small>		5	○○○
<b>Gusseisen</b> <small>Grau- / Kugelgraphitguss</small>	< 32 HRC	6a	●○○
	> 32 HRC	6b	●○○
<b>Titan</b> <small>Titanlegierungen</small>	Rm < 600 N/mm <sup>2</sup>	7a	●○○
	600 < Rm N/mm <sup>2</sup>	7b	●○○
<b>Nickellegierungen</b> <small>Inconel, Hastelloy</small>	Rm < 1000 N/mm <sup>2</sup>	8a	●●●
	Rm > 1000 N/mm <sup>2</sup>	8b	●●●
<b>Kupfer, Messing, Bronze</b> <small>Kupferbasis</small>	Rm < 850 N/mm <sup>2</sup>	9a	○○○
	Rm > 850 N/mm <sup>2</sup>	9b	○○○
<b>Aluminium</b> <small>Aluminiumlegierungen</small>	Si < 0.5%	10a	○○○
	0.5% < Si < 5%	10b	○○○
	Si > 5%	10c	○○○
<b>Kunststoffe</b> <small>Technische Kunststoffe</small>	Thermoplast	11a	○○○
	Duroplast	11b	○○○
<b>Verbundwerkstoffe</b> <small>Faserverbundwerkstoffe</small>	Glasfaser / GFK	12a	○○○
	Kohlefaser / KFK	12b	○○○
<b>Edelmetalle</b> <small>Gold, Platin, Silber</small>	Gold	13a	○○○
	Platin	13b	○○○

## TECHNISCHE ZEICHNUNG

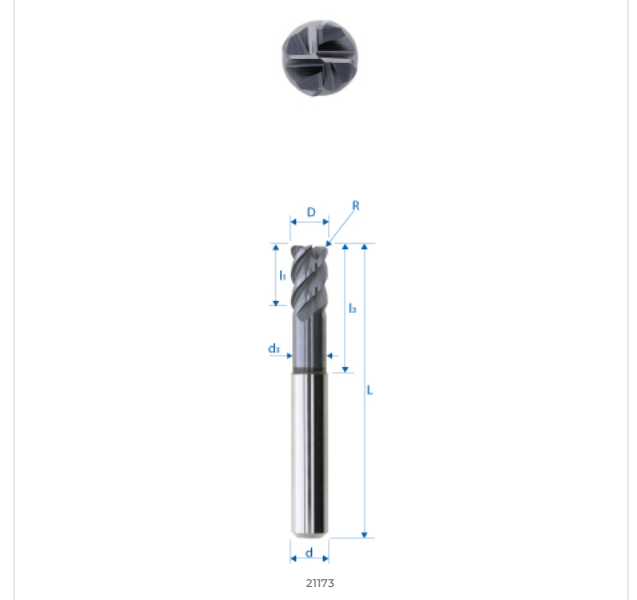

## ABMESSUNGEN

NENNMASS	
D (0 / -0.01)	12 mm
d (h5)	12 mm
L	83 mm
l1	18 mm
l3	37 mm
d3	-
R	2 mm
e	-
Z	4
Fase K	-
w° collision	-



E-SHOP / EZI CUT  
eskenazi.ch/eshop/22173A-12-R2

© 2026 Eskenazi SA — Carouge, Genève  
Alle Rechte vorbehalten