

FRAISE-PROFIL-ÉBAUCHE-MD-E2-+-EZI-ALPHA,- VERSION-COURTE · ROUGHIN-ENDMILL-SC-E2-+-EZI- ALPHA,-SHORT-VERSION · SCHAFT-SCHRUPPFÄSER- HM-E2-+-EZI-ALPHA,-KURTZE-VERSION



SWISS MADE

22520A-9-10

Version vom 08.05.2026

E2 E2 HOCHPRÄZISIONS- WERKSTOFF	$\lambda = 30^\circ$ $\gamma = 3^\circ$ SCHNEIDWINKEL $\approx 30^\circ$ $\approx 3^\circ$	45° 45° PRÄZISIONSWINKELMESSUNG	ZWEI-WEGE- SPIRALBOHRER	l_1 1.5xD 1.5XD TIEFE PRÄZISIONSWERKZEUG	KURZE LÄNGE WERKZEUGVERSCHLEISS BALKEN
--	---	--	----------------------------	---	--

WERKSTOFFKOMPATIBILITÄT

●●● Ausgezeichnet (3/3) ●●○ Gut (2/3) ●○○ Möglich (1/3) ○○○ Nicht empfohlen

WERKSTOFF	SPEZIFIKATION	GRP	22520A-9-10
Legierte und unlegierte Stähle Unlegierte Stähle	Rm < 450 N/mm ²	1a	●●○
	Rm 450–700 N/mm ²	1b	●●○
	Rm 700–900 N/mm ²	1c	●●○
	Rm > 1200 N/mm ²	1d	●○○
Rostfreie Stähle Rostfreie Stähle	Rm < 650 N/mm ²	2a	●●○
	Rm 650–950 N/mm ²	2b	●●○
	Rm > 950 N/mm ²	2c	●●○
Gehärtete Stähle Gehärtete Stähle	44–56 HRC	3a	○○○
	57–67 HRC	3b	○○○
Exotische Werkstoffe Speziallegierungen	< 32 HRC	4a	●○○
	> 32 HRC	4b	●○○
Graphit Industriegrphit		5	○○○
Gusseisen Grau- / Kugelgraphitguss	< 32 HRC	6a	●●●
	> 32 HRC	6b	●●●
Titan Titanlegierungen	Rm < 600 N/mm ²	7a	●●○
	600 < Rm N/mm ²	7b	●○○
Nickellegierungen Inconel, Hastelloy	Rm < 1000 N/mm ²	8a	●○○
	Rm > 1000 N/mm ²	8b	●○○
Kupfer, Messing, Bronze Kupferbasis	Rm < 850 N/mm ²	9a	●●○
	Rm > 850 N/mm ²	9b	●●○
Aluminium Aluminiumlegierungen	Si < 0.5%	10a	○○○
	0.5% < Si < 5%	10b	○○○
	Si > 5%	10c	○○○
Kunststoffe Technische Kunststoffe	Thermoplast	11a	○○○
	Duroplast	11b	○○○
Verbundwerkstoffe Faserverbundwerkstoffe	Glasfaser / GFK	12a	○○○
	Kohlefaser / KFK	12b	○○○
Edelmetalle Gold, Platin, Silber	Gold	13a	●●○
	Platin	13b	●○○

TECHNISCHE ZEICHNUNG

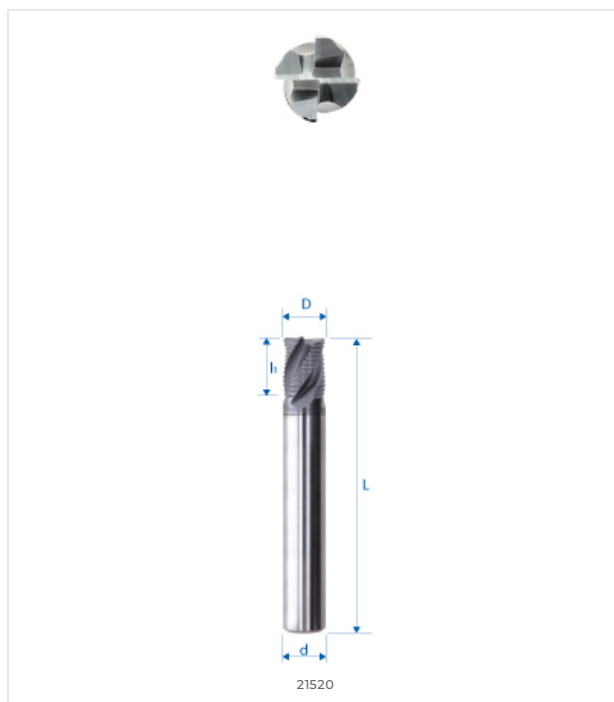

ABMESSUNGEN

NENNMASSE	
D (0 / -0.01)	9 mm
d (h5)	10 mm
L	66 mm
l1	10 mm
l3	–
d3	–
R	–
e	–
Z	4
Fase K	–
w° collision	2.5°



E-SHOP / EZI CUT
eskenazi.ch/eshop/22520A-9-10