

MICRO-FRAISE-HÉMISPHERIQUE Z2 · BALL-NOSE- MICRO-ENDMILL Z2 · MICRO-FRÄSER-HALBRUND Z2



21093A-1.2

Version 07.05.2026

SWISS MADE

| | | | | | | |
|---|--|--|---|---|---|---|
| <p>E25 UF</p> <p>CARBIDE TOOL MATERIAL E25 UF</p> | <p>$\lambda = 30^\circ$ $\gamma = 10^\circ$</p> <p>CUTTING ANGLES ? 30° ?10°</p> | <p>V-GROOVE CHAMFER TOOL SHAPE</p> | <p>DUAL DIRECTION HELICAL DRILL BIT</p> | <p>l_1 1.5xD</p> <p>1.5XD DEPTH PRECISION TOOL</p> | <p>l_3 8xD</p> <p>8XD LENGTH L3 CUTTING TOOL</p> | <p>STANDARD TOOL WEAR INDICATOR</p> |
|---|--|--|---|---|---|---|

MATERIAL COMPATIBILITY

●●● Excellent (3/3) ●●○ Good (2/3) ●○○ Possible (1/3) ○○○ Not recommended

| MATERIAL | SPECIFICATION | GRP | 21093A-1.2 |
|--|------------------------------|-----|------------|
| Alloyed and non-alloyed steels <small>Non-alloyed steels</small> | Rm < 450 N/mm ² | 1a | ●●● |
| | Rm 450–700 N/mm ² | 1b | ●●● |
| | Rm 700–900 N/mm ² | 1c | ●●● |
| | Rm > 1200 N/mm ² | 1d | ●●● |
| Stainless steels <small>Stainless steels</small> | Rm < 650 N/mm ² | 2a | ●●● |
| | Rm 650–950 N/mm ² | 2b | ●●● |
| | Rm > 950 N/mm ² | 2c | ●●● |
| Hardened steels <small>Hardened steels</small> | 44–56 HRC | 3a | ●●○ |
| | 57–67 HRC | 3b | ●○○ |
| Exotic materials <small>Special alloys</small> | < 32 HRC | 4a | ●●○ |
| | > 32 HRC | 4b | ●○○ |
| Graphite <small>Industrial graphite</small> | | 5 | ●●○ |
| Cast iron <small>Grey / nodular cast iron</small> | < 32 HRC | 6a | ●●○ |
| | > 32 HRC | 6b | ●●○ |
| Titanium <small>Titanium alloys</small> | Rm < 600 N/mm ² | 7a | ●●● |
| | 600 < Rm N/mm ² | 7b | ●●● |
| Nickel alloys <small>Inconel, Hastelloy</small> | Rm < 1000 N/mm ² | 8a | ●●○ |
| | Rm > 1000 N/mm ² | 8b | ●●○ |
| Copper, brass, bronze <small>Copper-based</small> | Rm < 850 N/mm ² | 9a | ●○○ |
| | Rm > 850 N/mm ² | 9b | ●○○ |
| Aluminum <small>Aluminum alloys</small> | Si < 0.5% | 10a | ●○○ |
| | 0.5% < Si < 5% | 10b | ●○○ |
| | Si > 5% | 10c | ●○○ |
| Synthetic materials <small>Engineering plastics</small> | Thermoplastic | 11a | ○○○ |
| | Thermoset | 11b | ○○○ |
| Composite materials <small>Reinforced composites</small> | Glass fiber / GFK | 12a | ●●○ |
| | Carbon fiber / KFK | 12b | ●●○ |
| Precious metals <small>Gold, platinum, silver</small> | Gold | 13a | ●●○ |
| | Platinum | 13b | ●○○ |

TECHNICAL DRAWING

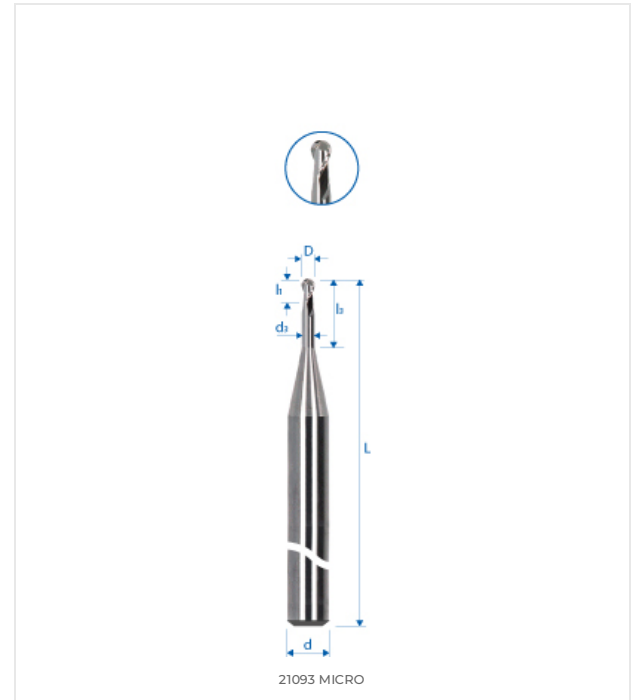

DIMENSIONS

| NOMINAL DIMENSIONS | |
|--------------------|--------|
| D (0 / -0.01) | 1.2 mm |
| d (h5) | 3 mm |
| L | 38 mm |
| l1 | 1.8 mm |
| l3 | 6 mm |
| d3 | – |
| R | 0.6 mm |
| e | – |
| Z | 2 |
| Chamfer K | – |
| w° collision | 5,5° |



E-SHOP / EZI CUT
eskenazi.ch/eshop/21093A-1.2