

# FRAISE-D'ÉBAUCHE-MD-E2+-EZI-ALPHA+L3-POUR-ACIERS · ROUGHING-ENDMILL-SC-E2+-EZI-ALPHA+L3-FOR-STEEL · SCHAFT-SCHRUPPFRÄSER-HM-E2+-EZI-ALPHA+L3-FÜR-STAHL



SWISS MADE

21134A-12 Version 07.05.2026

|  |   |   |                                      |  |                                   |                                     |                           |
|--|---|---|--------------------------------------|--|-----------------------------------|-------------------------------------|---------------------------|
| <b>E2</b><br>E2 HIGH PRECISION TOOL MATERIAL | $\lambda = 48^\circ$<br>$\gamma = 3^\circ$<br>CUTTING ANGLES $\gamma_{48^\circ} \gamma_{3^\circ}$ | 0.005-0.03<br>45°<br>45° CHAMFER TOLERANCE 0.005-0.03 | <br>DUAL DIRECTION HELICAL DRILL BIT | $l_1$<br>1.5xD<br>1.5XD DEPTH PRECISION TOOL | $l_3$<br>THREE-POINT CONTACT TOOL | <br>EXTRA LONG PRECISION DRILL BITS | <br>ADJUSTABLE ANGLE ICON |
|--|---|---|--------------------------------------|--|-----------------------------------|-------------------------------------|---------------------------|

## MATERIAL COMPATIBILITY

●●● Excellent (3/3) ●●○ Good (2/3) ●○○ Possible (1/3) ○○○ Not recommended

| MATERIAL  | SPECIFICATION                | GRP | 21134A-12 |
|---|------------------------------|-----|-----------|
| <b>Alloyed and non-alloyed steels</b><br>Non-alloyed steels | Rm < 450 N/mm <sup>2</sup>   | 1a  | ●●○       |
|   | Rm 450–700 N/mm <sup>2</sup> | 1b  | ●●○       |
|   | Rm 700–900 N/mm <sup>2</sup> | 1c  | ●●○       |
|   | Rm > 1200 N/mm <sup>2</sup>  | 1d  | ●●○       |
| <b>Stainless steels</b><br>Stainless steels                 | Rm < 650 N/mm <sup>2</sup>   | 2a  | ●●○       |
|   | Rm 650–950 N/mm <sup>2</sup> | 2b  | ●●○       |
|   | Rm > 950 N/mm <sup>2</sup>   | 2c  | ●●○       |
| <b>Hardened steels</b><br>Hardened steels                   | 44–56 HRC                    | 3a  | ●●○       |
|   | 57–67 HRC                    | 3b  | ●○○       |
| <b>Exotic materials</b><br>Special alloys                   | < 32 HRC                     | 4a  | ●●○       |
|   | > 32 HRC                     | 4b  | ●●○       |
| <b>Graphite</b><br>Industrial graphite                      |                              | 5   | ○○○       |
| <b>Cast iron</b><br>Grey / nodular cast iron                | < 32 HRC                     | 6a  | ●●○       |
|   | > 32 HRC                     | 6b  | ●●○       |
| <b>Titanium</b><br>Titanium alloys                          | Rm < 600 N/mm <sup>2</sup>   | 7a  | ●●○       |
|   | 600 < Rm N/mm <sup>2</sup>   | 7b  | ●●○       |
| <b>Nickel alloys</b><br>Inconel, Hastelloy                  | Rm < 1000 N/mm <sup>2</sup>  | 8a  | ●●○       |
|   | Rm > 1000 N/mm <sup>2</sup>  | 8b  | ●●○       |
| <b>Copper, brass, bronze</b><br>Copper-based                | Rm < 850 N/mm <sup>2</sup>   | 9a  | ○○○       |
|   | Rm > 850 N/mm <sup>2</sup>   | 9b  | ○○○       |
| <b>Aluminum</b><br>Aluminum alloys                          | Si < 0.5%                    | 10a | ○○○       |
|   | 0.5% < Si < 5%               | 10b | ○○○       |
|   | Si > 5%                      | 10c | ○○○       |
| <b>Synthetic materials</b><br>Engineering plastics          | Thermoplastic                | 11a | ○○○       |
|   | Thermoset                    | 11b | ○○○       |
| <b>Composite materials</b><br>Reinforced composites         | Glass fiber / GFK            | 12a | ○○○       |
|   | Carbon fiber / KFK           | 12b | ○○○       |
| <b>Precious metals</b><br>Gold, platinum, silver            | Gold                         | 13a | ○○○       |
|   | Platinum                     | 13b | ●○○       |

## TECHNICAL DRAWING

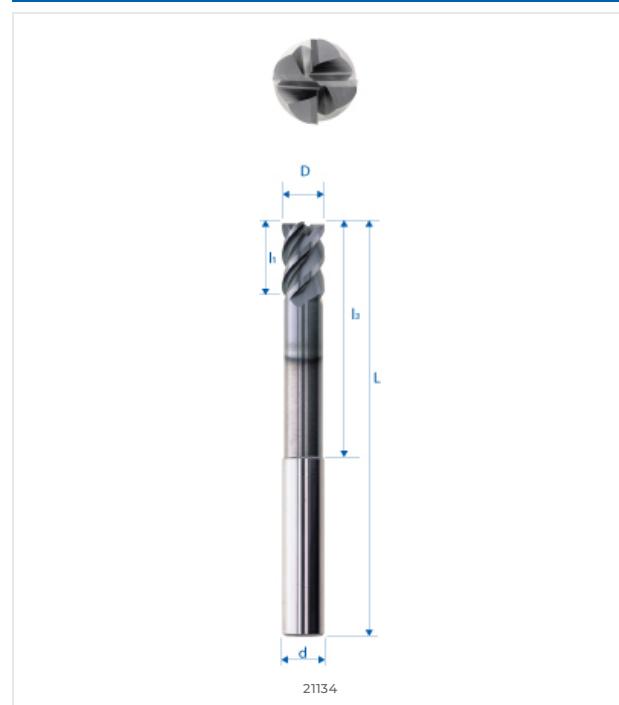

## DIMENSIONS

| NOMINAL DIMENSIONS |        |
|--------------------|--------|
| D (0 / -0.01)      | 12 mm  |
| d (h5)             | 12 mm  |
| L                  | 110 mm |
| l1                 | 18 mm  |
| l3                 | 64 mm  |
| d3                 | –      |
| R                  | –      |
| e                  | –      |
| Z                  | 4      |
| Chamfer K          | 0.1    |
| w° collision       | –      |



E-SHOP / EZI CUT  
[eskenazi.ch/eshop/21134A-12](https://eskenazi.ch/eshop/21134A-12)