

FRAISE-DE-FINITION-MD-E2 · FINISHING-ENDMILL-SC-E2

· SCHLICHTFRÄSER-HM-E2



21144-10

Version 07.05.2026

SWISS MADE

E2

E2 HIGH PRECISION
TOOL MATERIAL

$\lambda = 45^\circ$
 $\gamma = 8^\circ$

CUTTING ANGLES $\gamma 45^\circ \gamma$
8°

$\phi < \phi$ $\phi > \phi$
90° 45°

CHAMFER $\phi < \phi > \phi$ 90°
45°



DUAL DIRECTION
HELICAL DRILL BIT

l3
8xD

8XD LENGTH L3
CUTTING TOOL



TOOL LENGTH
MEASUREMENT BARS

MATERIAL COMPATIBILITY

●●● Excellent (3/3) ●●○ Good (2/3) ●○○ Possible (1/3) ○○○ Not recommended

MATERIAL	SPECIFICATION	GRP	21144-10
Alloyed and non-alloyed steels Non-alloyed steels	Rm < 450 N/mm ²	1a	●○○
	Rm 450–700 N/mm ²	1b	●○○
	Rm 700–900 N/mm ²	1c	○○○
	Rm > 1200 N/mm ²	1d	○○○
Stainless steels Stainless steels	Rm < 650 N/mm ²	2a	○○○
	Rm 650–950 N/mm ²	2b	○○○
	Rm > 950 N/mm ²	2c	○○○
Hardened steels Hardened steels	44–56 HRC	3a	○○○
	57–67 HRC	3b	○○○
Exotic materials Special alloys	< 32 HRC	4a	○○○
	> 32 HRC	4b	○○○
Graphite Industrial graphite		5	●●○
Cast iron Grey / nodular cast iron	< 32 HRC	6a	●○○
	> 32 HRC	6b	●○○
Titanium Titanium alloys	Rm < 600 N/mm ²	7a	●○○
	600 < Rm N/mm ²	7b	●○○
Nickel alloys Inconel, Hastelloy	Rm < 1000 N/mm ²	8a	○○○
	Rm > 1000 N/mm ²	8b	○○○
Copper, brass, bronze Copper-based	Rm < 850 N/mm ²	9a	●●●
	Rm > 850 N/mm ²	9b	●●●
Aluminum Aluminum alloys	Si < 0.5%	10a	●●○
	0.5% < Si < 5%	10b	●●○
	Si > 5%	10c	○○○
Synthetic materials Engineering plastics	Thermoplastic	11a	●●○
	Thermoset	11b	●●○
Composite materials Reinforced composites	Glass fiber / GFK	12a	●○○
	Carbon fiber / KFK	12b	●○○
Precious metals Gold, platinum, silver	Gold	13a	●●●
	Platinum	13b	●○○

TECHNICAL DRAWING

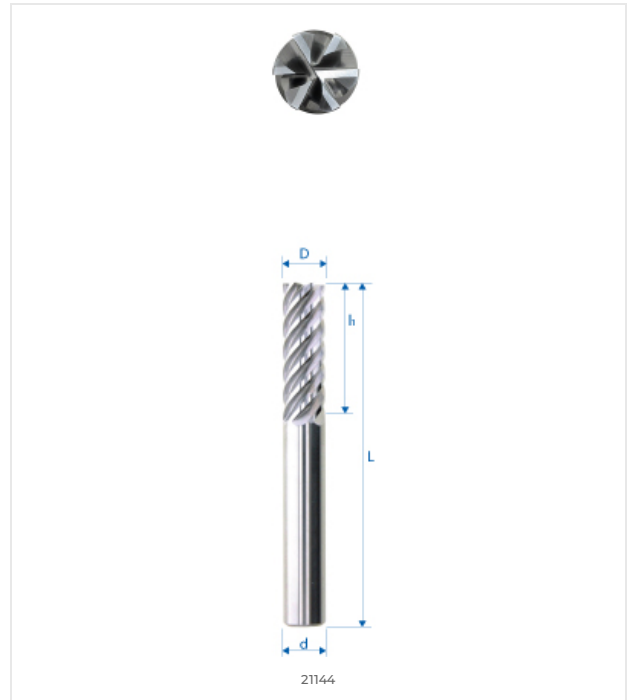

DIMENSIONS

NOMINAL DIMENSIONS

D (0 / -0.01)	10 mm
d (h5)	10 mm
L	72 mm
l1	28 mm
l3	–
d3	–
R	–
e	–
Z	6
Chamfer K	0.1
w° collision	–



E-SHOP / EZI CUT
eskenazi.ch/eshop/21144-10

© 2026 Eskenazi SA — Carouge, Genève
All rights reserved