

FRAISE-PROFIL-ÉBAUCHE-MD-E2-+-EZI-ALPHA · ROUGHIN-ENDMILL-SC-E2-+-EZI-ALPHA · SCHAFT- SCHRUPPFRÄSER-HM-E2-+-EZI-ALPHA



SWISS MADE

21510A-12 Version 21.06.2026

E2 E2 HIGH PRECISION TOOL MATERIAL	$\lambda = 30^\circ$ $\gamma = 3^\circ$ CUTTING ANGLES $\approx 30^\circ \pm 3^\circ$	45° 45° PRECISION ANGLE MEASUREMENT	 DUAL DIRECTION HELICAL DRILL BIT	h_1 2.2xD 2.2XD DEPTH FOR TOOLS	 STANDARD TOOL WEAR INDICATOR
---	---	--	---	--	-------------------------------------

MATERIAL COMPATIBILITY

●●● Excellent (3/3) ●●○ Good (2/3) ●○○ Possible (1/3) ○○○ Not recommended

MATERIAL	SPECIFICATION	GRP	21510A-12
Alloyed and non-alloyed steels Non-alloyed steels	Rm < 450 N/mm ²	1a	●●○
	Rm 450–700 N/mm ²	1b	●●○
	Rm 700–900 N/mm ²	1c	●●○
	Rm > 1200 N/mm ²	1d	●○○
Stainless steels Stainless steels	Rm < 650 N/mm ²	2a	●●○
	Rm 650–950 N/mm ²	2b	●●○
	Rm > 950 N/mm ²	2c	●●○
Hardened steels Hardened steels	44–56 HRC	3a	○○○
	57–67 HRC	3b	○○○
Exotic materials Special alloys	< 32 HRC	4a	●○○
	> 32 HRC	4b	●○○
Graphite Industrial graphite		5	○○○
Cast iron Grey / nodular cast iron	< 32 HRC	6a	●●●
	> 32 HRC	6b	●●●
Titanium Titanium alloys	Rm < 600 N/mm ²	7a	●●○
	600 < Rm N/mm ²	7b	●○○
Nickel alloys Inconel, Hastelloy	Rm < 1000 N/mm ²	8a	●○○
	Rm > 1000 N/mm ²	8b	●○○
Copper, brass, bronze Copper-based	Rm < 850 N/mm ²	9a	●●○
	Rm > 850 N/mm ²	9b	●●○
Aluminum Aluminum alloys	Si < 0.5%	10a	○○○
	0.5% < Si < 5%	10b	○○○
	Si > 5%	10c	○○○
Synthetic materials Engineering plastics	Thermoplastic	11a	○○○
	Thermoset	11b	○○○
Composite materials Reinforced composites	Glass fiber / GFK	12a	○○○
	Carbon fiber / KFK	12b	○○○
Precious metals Gold, platinum, silver	Gold	13a	●●○
	Platinum	13b	●○○

TECHNICAL DRAWING

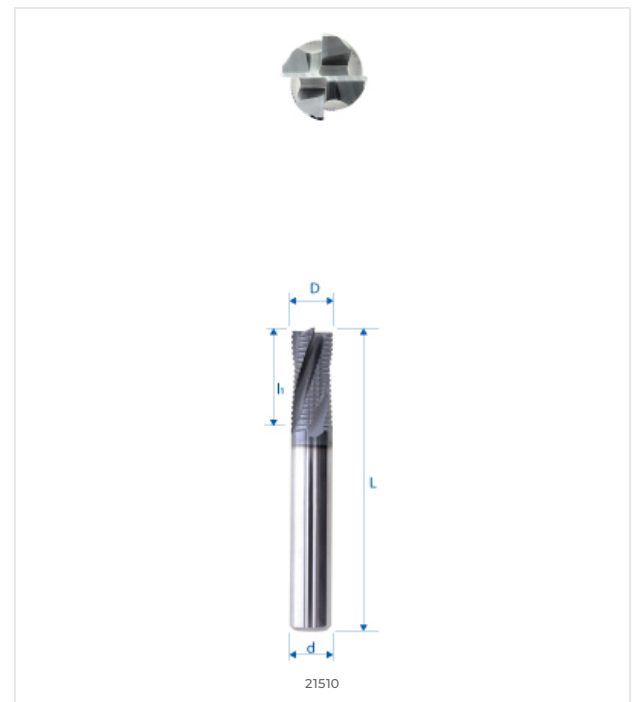

DIMENSIONS

NOMINAL DIMENSIONS	
D (0 / -0.01)	12 mm
d (h5)	12 mm
L	83 mm
l1	26 mm
l3	–
d3	–
R	–
e	–
Z	4
Chamfer K	0.3
w° collision	–



E-SHOP / EZI CUT
eskenazi.ch/eshop/21510A-12