

FRAISE-À-CHANFREINER-45°-MD-E2+-EZI-ALPHA ·  
 BEVEL-MILLING-CUTTER-45°-SC-E2+-EZI-ALPHA ·  
 FASENFRÄSER-45°-HM-E2+-EZI-ALPHA



SWISS MADE

21730A-10

Version 22.06.2026

E2

E2 HIGH PRECISION TOOL MATERIAL

$\lambda = 0^\circ$   
 $\gamma = 8^\circ$

TOOL ANGLES LAMBDA 0° GAMMA 8°



V-GROOVE CHAMFER TOOL SHAPE



LATERAL CUTTING TWIST DRILL BIT

MATERIAL COMPATIBILITY

●●● Excellent (3/3) ●● Good (2/3) ●○ Possible (1/3) ○○ Not recommended

MATERIAL	SPECIFICATION	GRP	21730A-10
<b>Alloyed and non-alloyed steels</b> Non-alloyed steels	Rm < 450 N/mm <sup>2</sup>	1a	●●●
	Rm 450–700 N/mm <sup>2</sup>	1b	●●●
	Rm 700–900 N/mm <sup>2</sup>	1c	●●●
	Rm > 1200 N/mm <sup>2</sup>	1d	●●●
<b>Stainless steels</b> Stainless steels	Rm < 650 N/mm <sup>2</sup>	2a	●●●
	Rm 650–950 N/mm <sup>2</sup>	2b	●●●
	Rm > 950 N/mm <sup>2</sup>	2c	●●●
<b>Hardened steels</b> Hardened steels	44–56 HRC	3a	●●○
	57–67 HRC	3b	●○○
<b>Exotic materials</b> Special alloys	< 32 HRC	4a	●●○
	> 32 HRC	4b	●●○
<b>Graphite</b> Industrial graphite		5	●●●
<b>Cast iron</b> Grey / nodular cast iron	< 32 HRC	6a	●●●
	> 32 HRC	6b	●●●
<b>Titanium</b> Titanium alloys	Rm < 600 N/mm <sup>2</sup>	7a	●●●
	600 < Rm N/mm <sup>2</sup>	7b	●●●
<b>Nickel alloys</b> Inconel, Hastelloy	Rm < 1000 N/mm <sup>2</sup>	8a	●●○
	Rm > 1000 N/mm <sup>2</sup>	8b	●●○
<b>Copper, brass, bronze</b> Copper-based	Rm < 850 N/mm <sup>2</sup>	9a	●●○
	Rm > 850 N/mm <sup>2</sup>	9b	●●○
<b>Aluminum</b> Aluminum alloys	Si < 0.5%	10a	●●○
	0.5% < Si < 5%	10b	●●○
	Si > 5%	10c	●●●
<b>Synthetic materials</b> Engineering plastics	Thermoplastic	11a	●○○
	Thermoset	11b	●○○
<b>Composite materials</b> Reinforced composites	Glass fiber / GFK	12a	●●●
	Carbon fiber / KFK	12b	●●●
<b>Precious metals</b> Gold, platinum, silver	Gold	13a	●●○
	Platinum	13b	●●○

TECHNICAL DRAWING

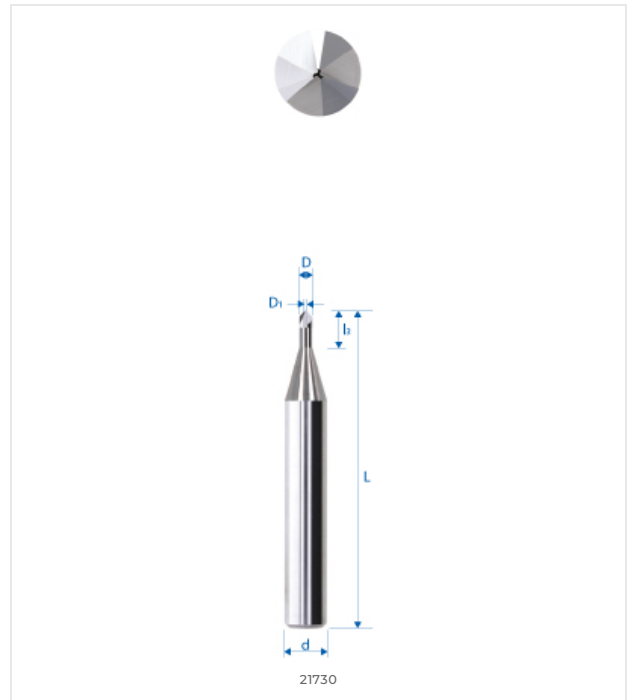

DIMENSIONS

NOMINAL DIMENSIONS

D (0 / -0.01)	10 mm
d (h5)	10 mm
L	72 mm
l1	4 mm
l3	-
d3	-
R	-
e	2 mm
Z	4
Chamfer K	-
w° collision	-



E-SHOP / EZI CUT  
 eskenazi.ch/eshop/21730A-10

© 2026 Eskenazi SA — Carouge, Genève  
 All rights reserved