

FRAISE-A-CHANFREINER-BI-FACE-90°-Z:1-MD-E25-UF-+-EZI-ALPHA-3 · BEVEL-MILLING-CUTTER-BI-FACE-90°-Z:1-CARBIDE-E25-UF-+-EZI-ALPHA-3 · FASENFRAESER-BI-FACE-90°-Z:1-HM-E25-UF-+-EZI-ALPHA-3



SWISS MADE

21735A-0.2

Version 06.05.2026

E2

E2 HIGH PRECISION TOOL MATERIAL

$\lambda = 0^\circ$   
 $\gamma = 8^\circ$

TOOL ANGLES LAMBDA 0° GAMMA 8°



BIFACE MULTI-POINT INTERFACE



LATERAL CUTTING TWIST DRILL BIT

MATERIAL COMPATIBILITY

●●● Excellent (3/3) ●●○ Good (2/3) ●○○ Possible (1/3) ○○○ Not recommended

MATERIAL	SPECIFICATION	GRP	21735A-0.2
<b>Alloyed and non-alloyed steels</b> Non-alloyed steels	Rm < 450 N/mm <sup>2</sup>	1a	●●●
	Rm 450–700 N/mm <sup>2</sup>	1b	●●●
	Rm 700–900 N/mm <sup>2</sup>	1c	●●●
	Rm > 1200 N/mm <sup>2</sup>	1d	●●●
<b>Stainless steels</b> Stainless steels	Rm < 650 N/mm <sup>2</sup>	2a	●●●
	Rm 650–950 N/mm <sup>2</sup>	2b	●●●
	Rm > 950 N/mm <sup>2</sup>	2c	●●●
<b>Hardened steels</b> Hardened steels	44–56 HRC	3a	●●○
	57–67 HRC	3b	●○○
<b>Exotic materials</b> Special alloys	< 32 HRC	4a	●●○
	> 32 HRC	4b	●●○
<b>Graphite</b> Industrial graphite		5	●●●
<b>Cast iron</b> Grey / nodular cast iron	< 32 HRC	6a	●●●
	> 32 HRC	6b	●●●
<b>Titanium</b> Titanium alloys	Rm < 600 N/mm <sup>2</sup>	7a	●●●
	600 < Rm N/mm <sup>2</sup>	7b	●●●
<b>Nickel alloys</b> Inconel, Hastelloy	Rm < 1000 N/mm <sup>2</sup>	8a	●●○
	Rm > 1000 N/mm <sup>2</sup>	8b	●●○
<b>Copper, brass, bronze</b> Copper-based	Rm < 850 N/mm <sup>2</sup>	9a	●●○
	Rm > 850 N/mm <sup>2</sup>	9b	●●○
<b>Aluminum</b> Aluminum alloys	Si < 0.5%	10a	●●○
	0.5% < Si < 5%	10b	●●○
	Si > 5%	10c	●●●
<b>Synthetic materials</b> Engineering plastics	Thermoplastic	11a	●○○
	Thermoset	11b	●○○
<b>Composite materials</b> Reinforced composites	Glass fiber / GFK	12a	●●●
	Carbon fiber / KFK	12b	●●●
<b>Precious metals</b> Gold, platinum, silver	Gold	13a	●●○
	Platinum	13b	●●○

TECHNICAL DRAWING

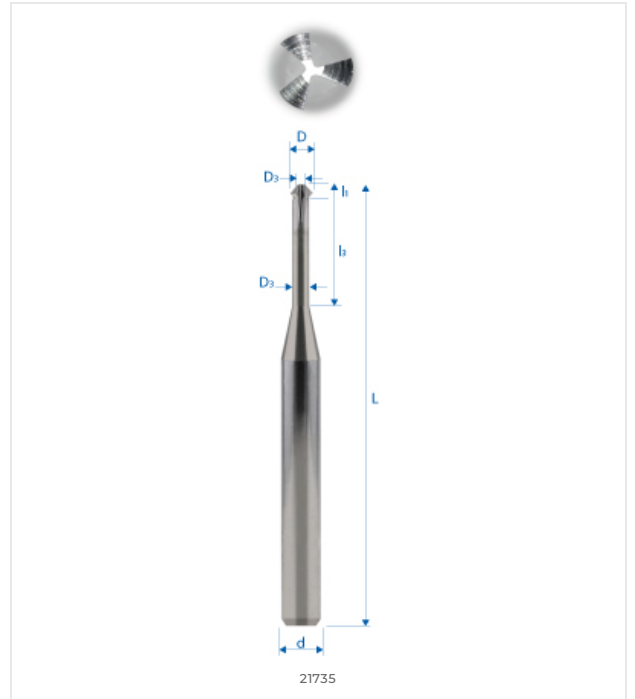

DIMENSIONS

NOMINAL DIMENSIONS

D (0 / -0.01)	0.2 mm
d (h5)	3 mm
L	38 mm
l1	0.08 mm
l3	0.4 mm
d3	–
R	–
e	–
Z	1
Chamfer K	–
w° collision	12.4°



E-SHOP / EZI CUT  
[eskenazi.ch/eshop/21735A-0.2](https://eskenazi.ch/eshop/21735A-0.2)