

FRAISE-A-CHANFREINER-BI-FACE-90°-Z:3-MD-E25-UF-+-
 EZI-ALPHA-3 · BEVEL-MILLING-CUTTER-BI-FACE-90°-Z:3-
 CARBIDE-E25-UF-+-EZI-ALPHA-3 · FASENFRAESER-BI-
 FACE-90°-Z:3-HM-E25-UF-+-EZI-ALPHA-3



SWISS MADE

21735A-2.5

Version 07.05.2026

E2

E2 HIGH PRECISION TOOL MATERIAL

$\lambda = 0^\circ$
 $\gamma = 8^\circ$

TOOL ANGLES LAMBDA 0° GAMMA 8°



BIFACE MULTI-POINT INTERFACE



LATERAL CUTTING TWIST DRILL BIT

MATERIAL COMPATIBILITY

●●● Excellent (3/3) ●●○ Good (2/3) ●○○ Possible (1/3) ○○○ Not recommended

| MATERIAL | SPECIFICATION | GRP | 21735A-2.5 |
|---|------------------------------|-----|------------|
| Alloyed and non-alloyed steels Non-alloyed steels | Rm < 450 N/mm ² | 1a | ●●● |
| | Rm 450–700 N/mm ² | 1b | ●●● |
| | Rm 700–900 N/mm ² | 1c | ●●● |
| | Rm > 1200 N/mm ² | 1d | ●●● |
| Stainless steels Stainless steels | Rm < 650 N/mm ² | 2a | ●●● |
| | Rm 650–950 N/mm ² | 2b | ●●● |
| | Rm > 950 N/mm ² | 2c | ●●● |
| Hardened steels Hardened steels | 44–56 HRC | 3a | ●●○ |
| | 57–67 HRC | 3b | ●○○ |
| Exotic materials Special alloys | < 32 HRC | 4a | ●●○ |
| | > 32 HRC | 4b | ●●○ |
| Graphite Industrial graphite | | 5 | ●●● |
| Cast iron Grey / nodular cast iron | < 32 HRC | 6a | ●●● |
| | > 32 HRC | 6b | ●●● |
| Titanium Titanium alloys | Rm < 600 N/mm ² | 7a | ●●● |
| | 600 < Rm N/mm ² | 7b | ●●● |
| Nickel alloys Inconel, Hastelloy | Rm < 1000 N/mm ² | 8a | ●●○ |
| | Rm > 1000 N/mm ² | 8b | ●●○ |
| Copper, brass, bronze Copper-based | Rm < 850 N/mm ² | 9a | ●●○ |
| | Rm > 850 N/mm ² | 9b | ●●○ |
| Aluminum Aluminum alloys | Si < 0.5% | 10a | ●●○ |
| | 0.5% < Si < 5% | 10b | ●●○ |
| | Si > 5% | 10c | ●●● |
| Synthetic materials Engineering plastics | Thermoplastic | 11a | ●○○ |
| | Thermoset | 11b | ●○○ |
| Composite materials Reinforced composites | Glass fiber / GFK | 12a | ●●● |
| | Carbon fiber / KFK | 12b | ●●● |
| Precious metals Gold, platinum, silver | Gold | 13a | ●●○ |
| | Platinum | 13b | ●●○ |

TECHNICAL DRAWING

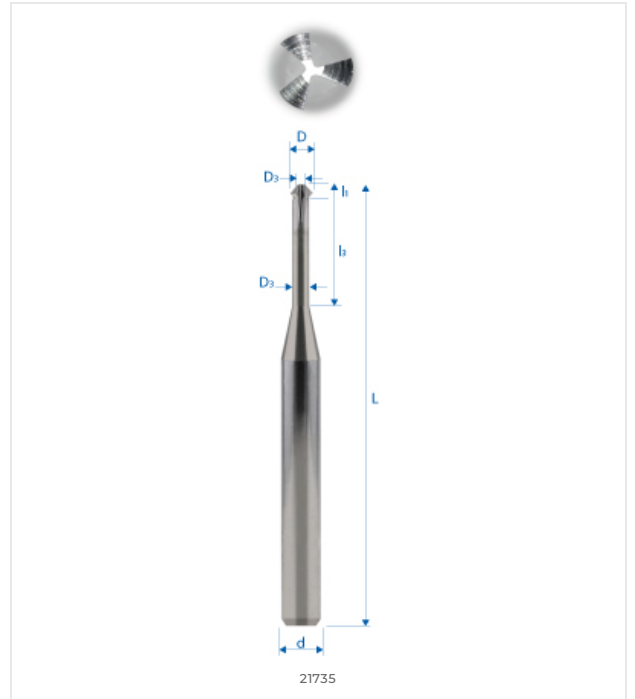

DIMENSIONS

NOMINAL DIMENSIONS

| | |
|---------------|--------|
| D (0 / -0.01) | 2.5 mm |
| d (h5) | 3 mm |
| L | 50 mm |
| l1 | 0.6 mm |
| l3 | 7.5 mm |
| d3 | – |
| R | – |
| e | – |
| Z | 3 |
| Chamfer K | – |
| w° collision | 1.8° |



E-SHOP / EZI CUT
eskenazi.ch/eshop/21735A-2.5