

FRAISE-D'ÉBAUCHE-MD-E2+-EZI-ALPHA+L3-POUR-ACIERS · ROUGHING-ENDMILL-SC-E2+-EZI-ALPHA+L3-FOR-STEEL · SCHAFT-SCHRUPPFRÄSER-HM-E2+-EZI-ALPHA+L3-FÜR-STAHL



SWISS MADE

22134A-6

Version 07.05.2026

E2 E2 HIGH PRECISION TOOL MATERIAL	$\lambda = 48^\circ$ $\gamma = 3^\circ$ CUTTING ANGLES $\gamma_{48^\circ} \gamma_{3^\circ}$	0.005-0.03 45° 45° CHAMFER TOLERANCE 0.005-0.03	 DUAL DIRECTION HELICAL DRILL BIT	l_1 1.5xD 1.5XD DEPTH PRECISION TOOL	l_3 THREE-POINT CONTACT TOOL	 EXTRA LONG PRECISION DRILL BITS	 ADJUSTABLE ANGLE ICON
--	---	---	--------------------------------------	--	-----------------------------------	-------------------------------------	---------------------------

MATERIAL COMPATIBILITY

●●● Excellent (3/3) ●●○ Good (2/3) ●○○ Possible (1/3) ○○○ Not recommended

MATERIAL	SPECIFICATION	GRP	22134A-6
Alloyed and non-alloyed steels <small>Non-alloyed steels</small>	Rm < 450 N/mm ²	1a	●●○
	Rm 450–700 N/mm ²	1b	●●○
	Rm 700–900 N/mm ²	1c	●●○
	Rm > 1200 N/mm ²	1d	●●○
Stainless steels <small>Stainless steels</small>	Rm < 650 N/mm ²	2a	●●○
	Rm 650–950 N/mm ²	2b	●●○
	Rm > 950 N/mm ²	2c	●●○
Hardened steels <small>Hardened steels</small>	44–56 HRC	3a	●●○
	57–67 HRC	3b	●○○
Exotic materials <small>Special alloys</small>	< 32 HRC	4a	●●○
	> 32 HRC	4b	●●○
Graphite <small>Industrial graphite</small>		5	○○○
Cast iron <small>Grey / nodular cast iron</small>	< 32 HRC	6a	●●○
	> 32 HRC	6b	●●○
Titanium <small>Titanium alloys</small>	Rm < 600 N/mm ²	7a	●●○
	600 < Rm N/mm ²	7b	●●○
Nickel alloys <small>Inconel, Hastelloy</small>	Rm < 1000 N/mm ²	8a	●●○
	Rm > 1000 N/mm ²	8b	●●○
Copper, brass, bronze <small>Copper-based</small>	Rm < 850 N/mm ²	9a	○○○
	Rm > 850 N/mm ²	9b	○○○
Aluminum <small>Aluminum alloys</small>	Si < 0.5%	10a	○○○
	0.5% < Si < 5%	10b	○○○
	Si > 5%	10c	○○○
Synthetic materials <small>Engineering plastics</small>	Thermoplastic	11a	○○○
	Thermoset	11b	○○○
Composite materials <small>Reinforced composites</small>	Glass fiber / GFK	12a	○○○
	Carbon fiber / KFK	12b	○○○
Precious metals <small>Gold, platinum, silver</small>	Gold	13a	○○○
	Platinum	13b	●○○

TECHNICAL DRAWING

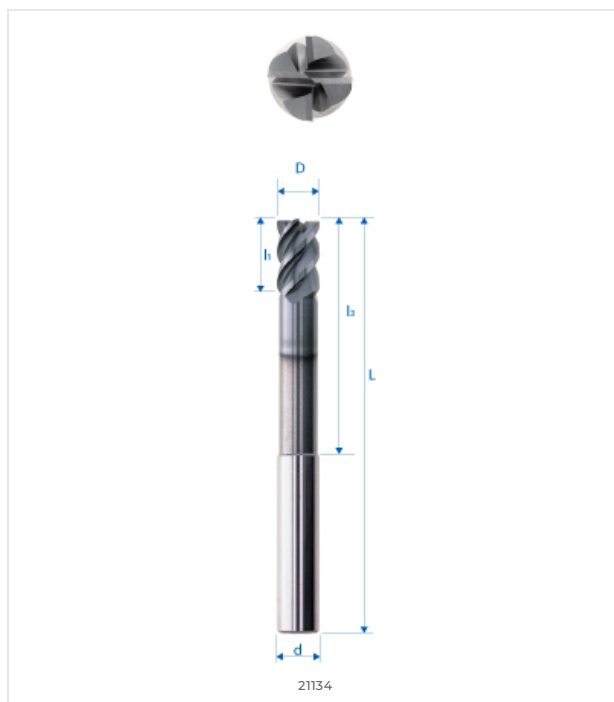

DIMENSIONS

NOMINAL DIMENSIONS	
D (0 / -0.01)	6 mm
d (h5)	6 mm
L	68 mm
l1	9 mm
l3	33 mm
d3	–
R	–
e	–
Z	3
Chamfer K	0.1
w° collision	–



E-SHOP / EZI CUT
eskenazi.ch/eshop/22134A-6