

E2 E2 HIGH PRECISION TOOL MATERIAL	$\lambda=35^{\circ}\text{-}38^{\circ}$ $\gamma=10^{\circ}$ CUTTING ANGLES γ 35-38° γ 10°	$\phi \leq 6$ $\phi > 6$ 90° 45° CHAMFER $\phi < 6$ $\phi > 6$ 90° 45°	 DUAL DIRECTION HELICAL DRILL BIT	l_1 4xD 4XD DRILLING DEPTH INDICATOR	 EXTRA LONG PRECISION DRILL BITS
--	--	--	--------------------------------------	--	-------------------------------------

MATERIAL COMPATIBILITY

●●● Excellent (3/3) ●●○ Good (2/3) ●○○ Possible (1/3) ○○○ Not recommended

MATERIAL	SPECIFICATION	GRP	22345A-20
Alloyed and non-alloyed steels Non-alloyed steels	Rm < 450 N/mm ²	1a	●●●
	Rm 450–700 N/mm ²	1b	●●●
	Rm 700–900 N/mm ²	1c	●●●
	Rm > 1200 N/mm ²	1d	●●○
Stainless steels Stainless steels	Rm < 650 N/mm ²	2a	●●●
	Rm 650–950 N/mm ²	2b	●●●
	Rm > 950 N/mm ²	2c	●●○
Hardened steels Hardened steels	44–56 HRC	3a	○○○
	57–67 HRC	3b	○○○
Exotic materials Special alloys	< 32 HRC	4a	●○○
	> 32 HRC	4b	●○○
Graphite Industrial graphite		5	●●○
Cast iron Grey / nodular cast iron	< 32 HRC	6a	●●●
	> 32 HRC	6b	●●●
Titanium Titanium alloys	Rm < 600 N/mm ²	7a	●●○
	600 < Rm N/mm ²	7b	●●○
Nickel alloys Inconel, Hastelloy	Rm < 1000 N/mm ²	8a	●○○
	Rm > 1000 N/mm ²	8b	●○○
Copper, brass, bronze Copper-based	Rm < 850 N/mm ²	9a	●●●
	Rm > 850 N/mm ²	9b	●●●
Aluminum Aluminum alloys	Si < 0.5%	10a	●●○
	0.5% < Si < 5%	10b	●○○
	Si > 5%	10c	●●○
Synthetic materials Engineering plastics	Thermoplastic	11a	●○○
	Thermoset	11b	●●○
Composite materials Reinforced composites	Glass fiber / GFK	12a	●●○
	Carbon fiber / KFK	12b	●●○
Precious metals Gold, platinum, silver	Gold	13a	●○○
	Platinum	13b	●○○

TECHNICAL DRAWING

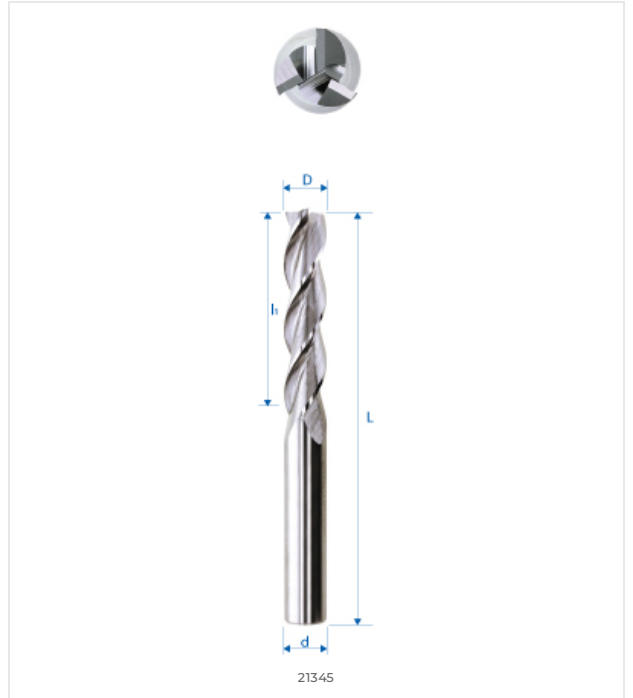

DIMENSIONS

NOMINAL DIMENSIONS	
D (0 / -0.01)	20 mm
d (h5)	20 mm
L	141 mm
l1	75 mm
l3	–
d3	–
R	–
e	–
Z	5
Chamfer K	0.1
w° collision	–

