

FRAISE-UGV-MD-E2-+-EZI-DUR-POUR-MÉTAUX-DURS · ENDMILL-FOR-HSC-E2-+-EZI-DUR- · SCHAFTFRÄSER- HSC-HM-E2-+-EZI-DUR-



SWISS MADE

23141X-3-6

Version 07.05.2026



MATERIAL COMPATIBILITY

●●● Excellent (3/3) ●●○ Good (2/3) ●○○ Possible (1/3) ○○○ Not recommended

MATERIAL	SPECIFICATION	GRP	23141X-3-6
Alloyed and non-alloyed steels <small>Non-alloyed steels</small>	Rm < 450 N/mm ²	1a	●○○
	Rm 450–700 N/mm ²	1b	●○○
	Rm 700–900 N/mm ²	1c	●○○
	Rm > 1200 N/mm ²	1d	●●●
Stainless steels <small>Stainless steels</small>	Rm < 650 N/mm ²	2a	●○○
	Rm 650–950 N/mm ²	2b	●○○
	Rm > 950 N/mm ²	2c	●○○
Hardened steels <small>Hardened steels</small>	44–56 HRC	3a	●●●
	57–67 HRC	3b	●●●
Exotic materials <small>Special alloys</small>	< 32 HRC	4a	●●●
	> 32 HRC	4b	●●●
Graphite <small>Industrial graphite</small>		5	●○○
Cast iron <small>Grey / nodular cast iron</small>	< 32 HRC	6a	●○○
	> 32 HRC	6b	●○○
Titanium <small>Titanium alloys</small>	Rm < 600 N/mm ²	7a	●○○
	600 < Rm N/mm ²	7b	●●○
Nickel alloys <small>Inconel, Hastelloy</small>	Rm < 1000 N/mm ²	8a	●●●
	Rm > 1000 N/mm ²	8b	●●●
Copper, brass, bronze <small>Copper-based</small>	Rm < 850 N/mm ²	9a	○○○
	Rm > 850 N/mm ²	9b	○○○
Aluminum <small>Aluminum alloys</small>	Si < 0.5%	10a	○○○
	0.5% < Si < 5%	10b	○○○
	Si > 5%	10c	○○○
Synthetic materials <small>Engineering plastics</small>	Thermoplastic	11a	○○○
	Thermoset	11b	○○○
Composite materials <small>Reinforced composites</small>	Glass fiber / GFK	12a	○○○
	Carbon fiber / KFK	12b	○○○
Precious metals <small>Gold, platinum, silver</small>	Gold	13a	○○○
	Platinum	13b	○○○

TECHNICAL DRAWING

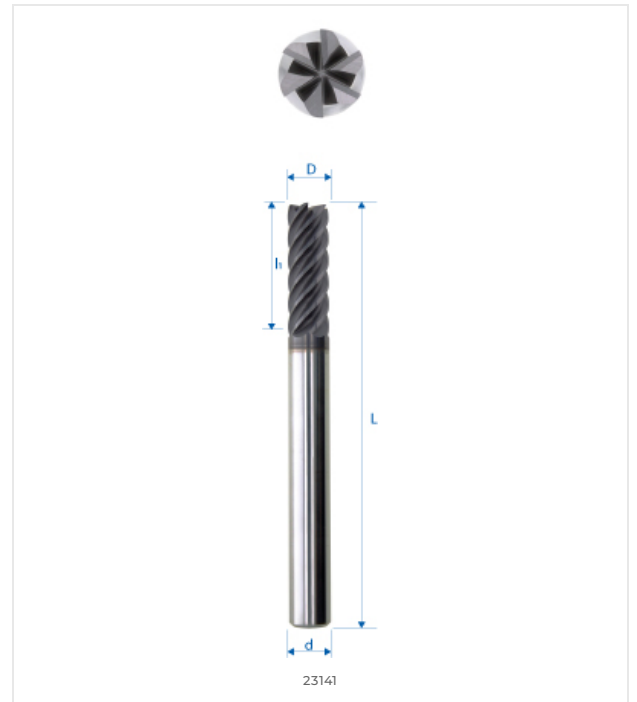

DIMENSIONS

NOMINAL DIMENSIONS	
D (0 / -0.01)	3 mm
d (h5)	6 mm
L	68 mm
l1	10 mm
l3	–
d3	–
R	–
e	–
Z	4
Chamfer K	0.03
w° collision	5.5°



E-SHOP / EZI CUT
eskenazi.ch/eshop/23141X-3-6