

E2 E2 HIGH PRECISION TOOL MATERIAL	$\lambda = 48^\circ$ $\gamma = 0^\circ$ CUTTING ANGLES $\gamma 48^\circ \gamma 0^\circ$	0.05-0.15 45° 45° CHAMFER 0.05-0.15 MM	 DUAL DIRECTION HELICAL DRILL BIT	l_1 1.5xD 1.5XD DEPTH PRECISION TOOL	l_3 THREE-POINT CONTACT TOOL	 STANDARD TOOL WEAR INDICATOR	 ADJUSTABLE ANGLE ICON
--	---	--	--------------------------------------	--	-----------------------------------	----------------------------------	---------------------------

MATERIAL COMPATIBILITY

●●● Excellent (3/3) ●●○ Good (2/3) ●○○ Possible (1/3) ○○○ Not recommended

MATERIAL	SPECIFICATION	GRP	28139A-1
Alloyed and non-alloyed steels <small>Non-alloyed steels</small>	Rm < 450 N/mm ²	1a	●●●
	Rm 450-700 N/mm ²	1b	●●●
	Rm 700-900 N/mm ²	1c	●●●
	Rm > 1200 N/mm ²	1d	●●○
Stainless steels <small>Stainless steels</small>	Rm < 650 N/mm ²	2a	●●●
	Rm 650-950 N/mm ²	2b	●●●
	Rm > 950 N/mm ²	2c	●●●
Hardened steels <small>Hardened steels</small>	44-56 HRC	3a	●●○
	57-67 HRC	3b	●○○
Exotic materials <small>Special alloys</small>	< 32 HRC	4a	●●●
	> 32 HRC	4b	●●●
Graphite <small>Industrial graphite</small>		5	○○○
Cast iron <small>Grey / nodular cast iron</small>	< 32 HRC	6a	●●●
	> 32 HRC	6b	●●●
Titanium <small>Titanium alloys</small>	Rm < 600 N/mm ²	7a	●●●
	600 < Rm N/mm ²	7b	●●●
Nickel alloys <small>Inconel, Hastelloy</small>	Rm < 1000 N/mm ²	8a	●●●
	Rm > 1000 N/mm ²	8b	●●●
Copper, brass, bronze <small>Copper-based</small>	Rm < 850 N/mm ²	9a	○○○
	Rm > 850 N/mm ²	9b	○○○
Aluminum <small>Aluminum alloys</small>	Si < 0.5%	10a	○○○
	0.5% < Si < 5%	10b	○○○
	Si > 5%	10c	○○○
Synthetic materials <small>Engineering plastics</small>	Thermoplastic	11a	○○○
	Thermoset	11b	○○○
Composite materials <small>Reinforced composites</small>	Glass fiber / GFK	12a	○○○
	Carbon fiber / KFK	12b	○○○
Precious metals <small>Gold, platinum, silver</small>	Gold	13a	○○○
	Platinum	13b	●○○

TECHNICAL DRAWING

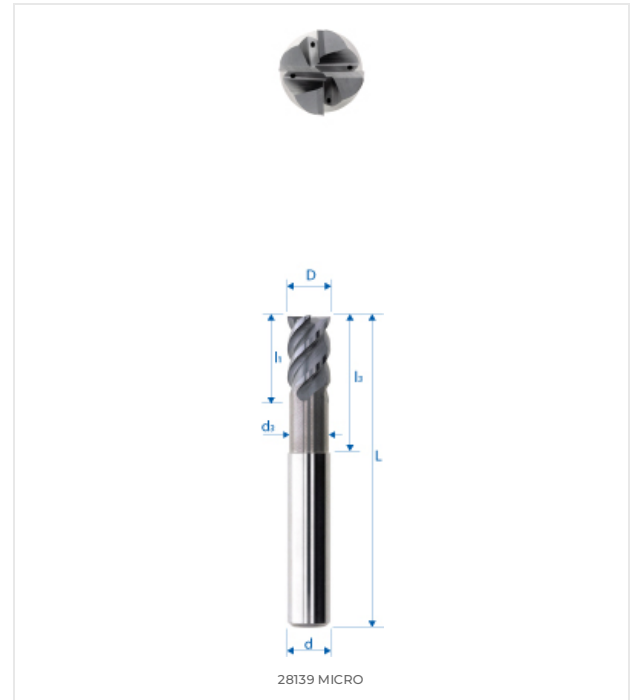

DIMENSIONS

NOMINAL DIMENSIONS	
D (0 / -0.01)	1 mm
d (h5)	3 mm
L	38 mm
l1	1.5 mm
l3	3 mm
d3	-
R	-
e	-
Z	3
Chamfer K	0.1
w° collision	8.1°



E-SHOP / EZI CUT
eskenazi.ch/eshop/28139A-1