

MICRO-FRAISE-HÉMISPHERIQUE Z2 · BALL-NOSE- MICRO-ENDMILL Z2 · MICRO-FRÄSER-HALBRUND Z2



21093A-1.5

Version du 07.05.2026

SWISS MADE



COMPATIBILITÉ MATIÈRE

●●● Excellent (3/3) ●● Bon (2/3) ●○ Possible (1/3) ○○ Non recommandé

| MATIÈRE | SPÉCIFICATION | GRP | 21093A-1.5 |
|--|------------------------------|-----|------------|
| Aciers alliés et non alliés <small>Aciers non alliés</small> | Rm < 450 N/mm ² | 1a | ●●● |
| | Rm 450–700 N/mm ² | 1b | ●●● |
| | Rm 700–900 N/mm ² | 1c | ●●● |
| | Rm > 1200 N/mm ² | 1d | ●●● |
| Aciers Inox <small>Aciers inoxydables</small> | Rm < 650 N/mm ² | 2a | ●●● |
| | Rm 650–950 N/mm ² | 2b | ●●● |
| | Rm > 950 N/mm ² | 2c | ●●● |
| Aciers trempés <small>Aciers durcis</small> | 44–56 HRC | 3a | ●●○ |
| | 57–67 HRC | 3b | ●○○ |
| Matériaux exotiques <small>Alliages spéciaux</small> | < 32 HRC | 4a | ●●○ |
| | > 32 HRC | 4b | ●○○ |
| Graphite <small>Graphite industriel</small> | | 5 | ●●○ |
| Fontes <small>Fonte grise / nodulaire</small> | < 32 HRC | 6a | ●●○ |
| | > 32 HRC | 6b | ●●○ |
| Titane <small>Alliages titane</small> | Rm < 600 N/mm ² | 7a | ●●● |
| | 600 < Rm N/mm ² | 7b | ●●● |
| Alliages Nickel <small>Inconel, Hastelloy</small> | Rm < 1000 N/mm ² | 8a | ●●○ |
| | Rm > 1000 N/mm ² | 8b | ●●○ |
| Cuivre, laiton, bronze <small>Cuivreux</small> | Rm < 850 N/mm ² | 9a | ●○○ |
| | Rm > 850 N/mm ² | 9b | ●○○ |
| Aluminium <small>Alliages aluminium</small> | Si < 0.5% | 10a | ●○○ |
| | 0.5% < Si < 5% | 10b | ●○○ |
| | Si > 5% | 10c | ●○○ |
| Matériaux synthétiques <small>Plastiques techniques</small> | Thermoplastique | 11a | ○○○ |
| | Thermodurcissable | 11b | ○○○ |
| Matériaux composites <small>Composites renforcés</small> | Fibre de verre / GFK | 12a | ●●○ |
| | Fibre de carbone / KFK | 12b | ●●○ |
| Métaux précieux <small>Or, platine, argent</small> | Or | 13a | ●●○ |
| | Platine | 13b | ●○○ |

DESSIN TECHNIQUE

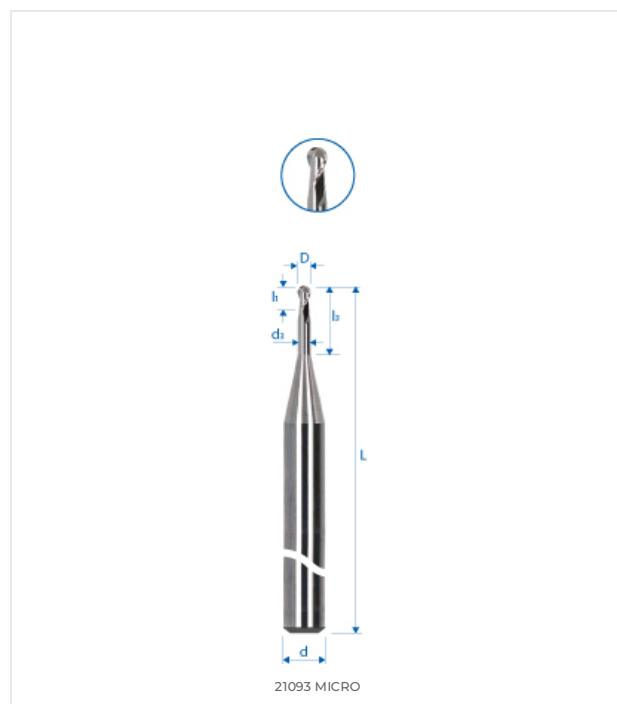

DIMENSIONS

| DIMENSIONS NOMINALES | |
|----------------------|---------|
| D (0 / -0.01) | 1.5 mm |
| d (h5) | 3 mm |
| L | 38 mm |
| l1 | 2.25 mm |
| l3 | 7.5 mm |
| d3 | – |
| R | 0.75 mm |
| e | – |
| Z | 2 |
| Chanfrein K | – |
| w° collision | 4.2° |



E-SHOP / EZI CUT
eskenazi.ch/eshop/21093A-1.5