

E2 OUTIL E2 MATÉRIAU HAUTE PRÉCISION	$\lambda=35^{\circ}-38^{\circ}$ $\gamma=10^{\circ}$ ANGLES DE COUPE ?35-38° ? 10°	angle vif ANGLE VIF OUTIL PRÉCISION	 FORET HÉLICOÏDAL À DOUBLE SENS	l_1 1.5xD PROFONDEUR 1.5xD OUTIL PRÉCISION	 BARRÉS LONGUEUR COURTE USURE OUTIL	 ICÔNE D'ANGLES RÉGLABLES	 FORET À HÉLICE VARIABLE
--	---	--	--	--	---	------------------------------------	-----------------------------------

COMPATIBILITÉ MATIÈRE

●●● Excellent (3/3) ●●○ Bon (2/3) ●○○ Possible (1/3) ○○○ Non recommandé

MATIÈRE	SPÉCIFICATION	GRP	2111A-2-6
Aciers alliés et non alliés <small>Aciers non alliés</small>	Rm < 450 N/mm ²	1a	●●●
	Rm 450–700 N/mm ²	1b	●●●
	Rm 700–900 N/mm ²	1c	●●●
	Rm > 1200 N/mm ²	1d	●●●
Aciers Inox <small>Aciers inoxydables</small>	Rm < 650 N/mm ²	2a	●●●
	Rm 650–950 N/mm ²	2b	●●●
	Rm > 950 N/mm ²	2c	●●●
Aciers trempés <small>Aciers durcis</small>	44–56 HRC	3a	●○○
	57–67 HRC	3b	○○○
Matériaux exotiques <small>Alliages spéciaux</small>	< 32 HRC	4a	●●○
	> 32 HRC	4b	●●○
Graphite <small>Graphite industriel</small>		5	●●○
Fontes <small>Fonte grise / nodulaire</small>	< 32 HRC	6a	●●●
	> 32 HRC	6b	●●●
Titane <small>Alliages titane</small>	Rm < 600 N/mm ²	7a	●●●
	600 < Rm N/mm ²	7b	●●●
Alliages Nickel <small>Inconel, Hastelloy</small>	Rm < 1000 N/mm ²	8a	●●○
	Rm > 1000 N/mm ²	8b	●●○
Cuivre, laiton, bronze <small>Cuivreux</small>	Rm < 850 N/mm ²	9a	●○○
	Rm > 850 N/mm ²	9b	●○○
Aluminium <small>Alliages aluminium</small>	Si < 0.5%	10a	●○○
	0.5% < Si < 5%	10b	●○○
	Si > 5%	10c	●○○
Matières synthétiques <small>Plastiques techniques</small>	Thermoplastique	11a	○○○
	Thermodurcissable	11b	○○○
Matières composites <small>Composites renforcés</small>	Fibre de verre / GFK	12a	●●○
	Fibre de carbone / KFK	12b	●●○
Métaux précieux <small>Or, platine, argent</small>	Or	13a	●○○
	Platine	13b	●●○

DESSIN TECHNIQUE

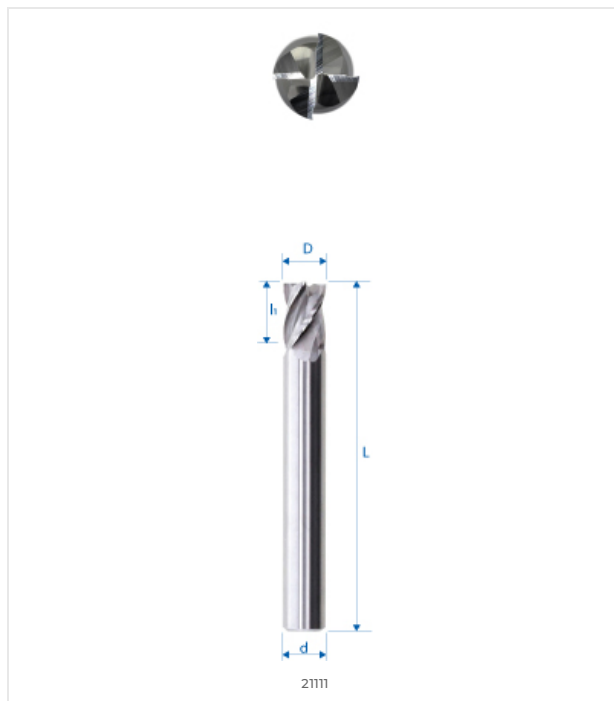

DIMENSIONS

DIMENSIONS NOMINALES	
D (0 / -0.01)	2 mm
d (h5)	6 mm
L	57 mm
l1	3 mm
l3	–
d3	–
R	–
e	–
Z	4
Chanfrein K	–
w° collision	10°



E-SHOP / EZI CUT
eskenazi.ch/eshop/21111A-2-6