

| | | | | | | | |
|------------------------------------------------------|-----------------------------------------------------------------------------------------------|----------------------------------------------|------------------------------------------|----------------------------------------------------------|-------------------------------------------------|------------------------------------|-----------------------------------|
| E2 OUTIL E2 MATÉRIAU HAUTE PRÉCISION | $\lambda=35^{\circ}-38^{\circ}$ $\gamma=10^{\circ}$ ANGLES DE COUPE ?35-38° ? 10° | angle vif ANGLE VIF OUTIL PRÉCISION | FORET HÉLICOÏDAL À DOUBLE SENS | l_1 1.5xD PROFONDEUR 1.5xD OUTIL PRÉCISION | BARRES LONGUEUR COURTE USURE OUTIL | ICÔNE D'ANGLES RÉGLABLES | FORET À HÉLICE VARIABLE |
|------------------------------------------------------|-----------------------------------------------------------------------------------------------|----------------------------------------------|------------------------------------------|----------------------------------------------------------|-------------------------------------------------|------------------------------------|-----------------------------------|

COMPATIBILITÉ MATIÈRE

●●● Excellent (3/3) ●●○ Bon (2/3) ●○○ Possible (1/3) ○○○ Non recommandé

| MATIÈRE | SPÉCIFICATION | GRP | 2111A-4-6 |
|------------------------------------------------------------------------|------------------------------|-----|-----------|
| Aciers alliés et non alliés <small>Aciers non alliés</small> | Rm < 450 N/mm ² | 1a | ●●● |
| | Rm 450–700 N/mm ² | 1b | ●●● |
| | Rm 700–900 N/mm ² | 1c | ●●● |
| | Rm > 1200 N/mm ² | 1d | ●●● |
| Aciers Inox <small>Aciers inoxydables</small> | Rm < 650 N/mm ² | 2a | ●●● |
| | Rm 650–950 N/mm ² | 2b | ●●● |
| | Rm > 950 N/mm ² | 2c | ●●● |
| Aciers trempés <small>Aciers durcis</small> | 44–56 HRC | 3a | ●○○ |
| | 57–67 HRC | 3b | ○○○ |
| Matériaux exotiques <small>Alliages spéciaux</small> | < 32 HRC | 4a | ●●○ |
| | > 32 HRC | 4b | ●●○ |
| Graphite <small>Graphite industriel</small> | | 5 | ●●○ |
| Fontes <small>Fonte grise / nodulaire</small> | < 32 HRC | 6a | ●●● |
| | > 32 HRC | 6b | ●●● |
| Titane <small>Alliages titane</small> | Rm < 600 N/mm ² | 7a | ●●● |
| | 600 < Rm N/mm ² | 7b | ●●● |
| Alliages Nickel <small>Inconel, Hastelloy</small> | Rm < 1000 N/mm ² | 8a | ●●○ |
| | Rm > 1000 N/mm ² | 8b | ●●○ |
| Cuivre, laiton, bronze <small>Cuivreux</small> | Rm < 850 N/mm ² | 9a | ●○○ |
| | Rm > 850 N/mm ² | 9b | ●○○ |
| Aluminium <small>Alliages aluminium</small> | Si < 0.5% | 10a | ●○○ |
| | 0.5% < Si < 5% | 10b | ●○○ |
| | Si > 5% | 10c | ●○○ |
| Matières synthétiques <small>Plastiques techniques</small> | Thermoplastique | 11a | ○○○ |
| | Thermodurcissable | 11b | ○○○ |
| Matières composites <small>Composites renforcés</small> | Fibre de verre / GFK | 12a | ●●○ |
| | Fibre de carbone / KFK | 12b | ●●○ |
| Métaux précieux <small>Or, platine, argent</small> | Or | 13a | ●○○ |
| | Platine | 13b | ●●○ |

DESSIN TECHNIQUE

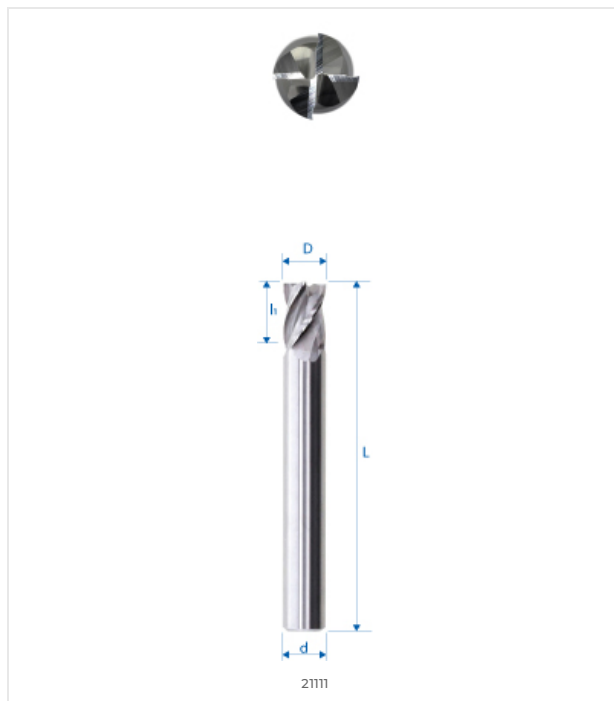

DIMENSIONS

| DIMENSIONS NOMINALES | |
|----------------------|-------|
| D (0 / -0.01) | 4 mm |
| d (h5) | 6 mm |
| L | 57 mm |
| l1 | 6 mm |
| l3 | – |
| d3 | – |
| R | – |
| e | – |
| Z | 4 |
| Chanfrein K | – |
| w° collision | 5,8° |



E-SHOP / EZI CUT
eskenazi.ch/eshop/21111A-4-6