

# FRAISE-DE-FINITION-MD-E2+-EZI-ALPHA · FINISHING- ENDMILL-SC-E2+-EZI-ALPHA · SCHLICHTFRÄSER-HM-E2- +-EZI-ALPHA



SWISS MADE

21144A-10

Version du 07.05.2026

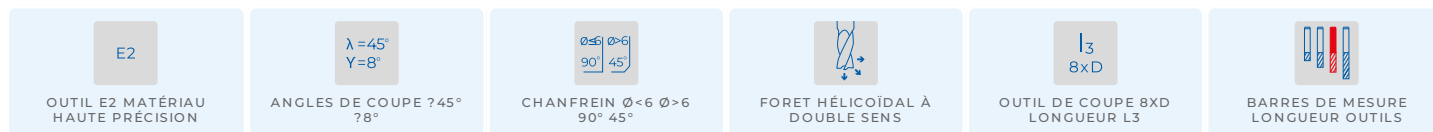

## COMPATIBILITÉ MATIÈRE

●●● Excellent (3/3) ●●○ Bon (2/3) ●○○ Possible (1/3) ○○○ Non recommandé

MATIÈRE	SPÉCIFICATION	GRP	21144A-10
<b>Aciers alliés et non alliés</b> Aciers non alliés	Rm < 450 N/mm <sup>2</sup>	1a	●●●
	Rm 450–700 N/mm <sup>2</sup>	1b	●●●
	Rm 700–900 N/mm <sup>2</sup>	1c	●●●
	Rm > 1200 N/mm <sup>2</sup>	1d	●●●
<b>Aciers Inox</b> Aciers inoxydables	Rm < 650 N/mm <sup>2</sup>	2a	●●●
	Rm 650–950 N/mm <sup>2</sup>	2b	●●●
	Rm > 950 N/mm <sup>2</sup>	2c	●●●
<b>Aciers trempés</b> Aciers durcis	44–56 HRC	3a	●●○
	57–67 HRC	3b	●○○
<b>Matériaux exotiques</b> Alliages spéciaux	< 32 HRC	4a	●●●
	> 32 HRC	4b	●●○
<b>Graphite</b> Graphite industriel		5	●●○
<b>Fontes</b> Fonte grise / nodulaire	< 32 HRC	6a	●●●
	> 32 HRC	6b	●●●
<b>Titane</b> Alliages titane	Rm < 600 N/mm <sup>2</sup>	7a	●●●
	600 < Rm N/mm <sup>2</sup>	7b	●●●
<b>Alliages Nickel</b> Inconel, Hastelloy	Rm < 1000 N/mm <sup>2</sup>	8a	●●○
	Rm > 1000 N/mm <sup>2</sup>	8b	●●○
<b>Cuivre, laiton, bronze</b> Cuivreux	Rm < 850 N/mm <sup>2</sup>	9a	●○○
	Rm > 850 N/mm <sup>2</sup>	9b	●○○
<b>Aluminium</b> Alliages aluminium	Si < 0.5%	10a	●○○
	0.5% < Si < 5%	10b	●○○
	Si > 5%	10c	●●○
<b>Matières synthétiques</b> Plastiques techniques	Thermoplastique	11a	●○○
	Thermodurcissable	11b	●○○
<b>Matières composites</b> Composites renforcés	Fibre de verre / GFK	12a	●○○
	Fibre de carbone / KFK	12b	●○○
<b>Métaux précieux</b> Or, platine, argent	Or	13a	●○○
	Platine	13b	●○○

## DESSIN TECHNIQUE

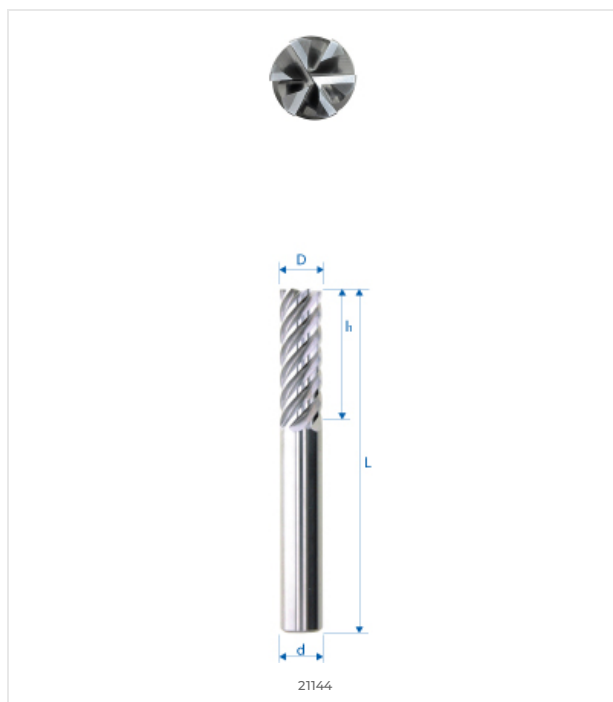

## DIMENSIONS

DIMENSIONS NOMINALES	
D (0 / -0.01)	10 mm
d (h5)	10 mm
L	72 mm
l1	28 mm
l3	–
d3	–
R	–
e	–
Z	6
Chanfrein K	0.1
w° collision	–



E-SHOP / EZI CUT  
[eskenazi.ch/eshop/21144A-10](https://eskenazi.ch/eshop/21144A-10)