

# FRAISE-DE-FINITION-MD-E2+-EZI-DUR · FINISHING- ENDMILL-SC-E2+-EZI-DUR · SCHLICHTFRÄSER-HM-E2+- EZI-DUR



SWISS MADE

21144X-6

Version du 07.05.2026

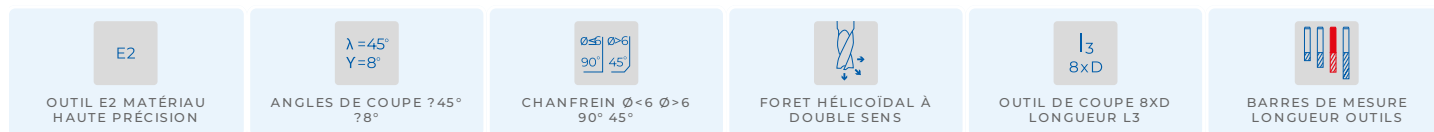

## COMPATIBILITÉ MATIÈRE

●●● Excellent (3/3) ●●○ Bon (2/3) ●○○ Possible (1/3) ○○○ Non recommandé

MATIÈRE	SPÉCIFICATION	GRP	21144X-6
<b>Aciers alliés et non alliés</b> <small>Aciers non alliés</small>	Rm < 450 N/mm <sup>2</sup>	1a	●●○
	Rm 450–700 N/mm <sup>2</sup>	1b	●●○
	Rm 700–900 N/mm <sup>2</sup>	1c	●●○
	Rm > 1200 N/mm <sup>2</sup>	1d	●●○
<b>Aciers Inox</b> <small>Aciers inoxydables</small>	Rm < 650 N/mm <sup>2</sup>	2a	●●○
	Rm 650–950 N/mm <sup>2</sup>	2b	●●○
	Rm > 950 N/mm <sup>2</sup>	2c	●●○
<b>Aciers trempés</b> <small>Aciers durcis</small>	44–56 HRC	3a	●●●
	57–67 HRC	3b	●●●
<b>Matériaux exotiques</b> <small>Alliages spéciaux</small>	< 32 HRC	4a	●●●
	> 32 HRC	4b	●●●
<b>Graphite</b> <small>Graphite industriel</small>		5	●○○
<b>Fontes</b> <small>Fonte grise / nodulaire</small>	< 32 HRC	6a	●●○
	> 32 HRC	6b	●●○
<b>Titane</b> <small>Alliages titane</small>	Rm < 600 N/mm <sup>2</sup>	7a	●●○
	600 < Rm N/mm <sup>2</sup>	7b	●●○
<b>Alliages Nickel</b> <small>Inconel, Hastelloy</small>	Rm < 1000 N/mm <sup>2</sup>	8a	●●●
	Rm > 1000 N/mm <sup>2</sup>	8b	●●●
<b>Cuivre, laiton, bronze</b> <small>Cuivreux</small>	Rm < 850 N/mm <sup>2</sup>	9a	○○○
	Rm > 850 N/mm <sup>2</sup>	9b	○○○
<b>Aluminium</b> <small>Alliages aluminium</small>	Si < 0.5%	10a	●○○
	0.5% < Si < 5%	10b	●○○
	Si > 5%	10c	●●○
<b>Matières synthétiques</b> <small>Plastiques techniques</small>	Thermoplastique	11a	○○○
	Thermodurcissable	11b	○○○
<b>Matières composites</b> <small>Composites renforcés</small>	Fibre de verre / GFK	12a	●○○
	Fibre de carbone / KFK	12b	●○○
<b>Métaux précieux</b> <small>Or, platine, argent</small>	Or	13a	●○○
	Platine	13b	●○○

## DESSIN TECHNIQUE

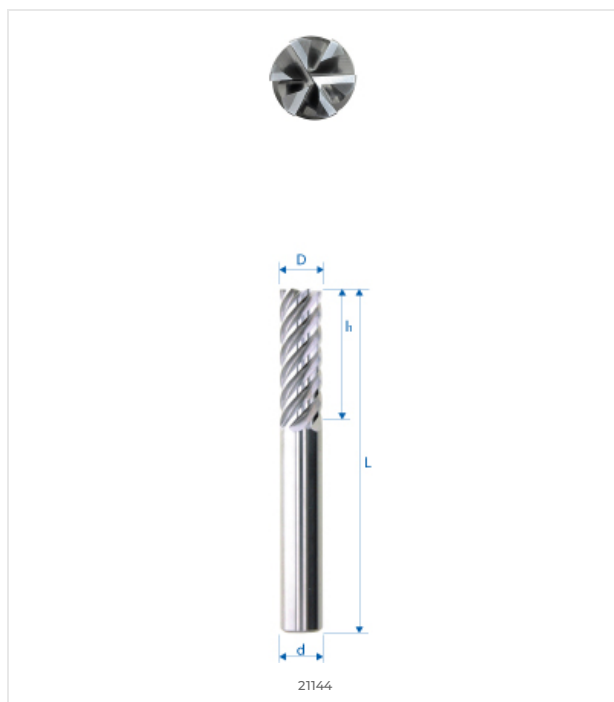

## DIMENSIONS

DIMENSIONS NOMINALES	
D (0 / -0.01)	6 mm
d (h5)	6 mm
L	57 mm
l1	18 mm
l3	–
d3	–
R	–
e	–
Z	6
Chanfrein K	–
w° collision	–



E-SHOP / EZI CUT  
[eskenazi.ch/eshop/21144X-6](https://eskenazi.ch/eshop/21144X-6)

© 2026 Eskenazi SA — Carouge, Genève  
Tous droits réservés