

FRAISE-A-CHANFREINER-BI-FACE-90°-Z:3-MD-E25-UF-+-EZI-ALPHA-3 · BEVEL-MILLING-CUTTER-BI-FACE-90°-Z:3-CARBIDE-E25-UF-+-EZI-ALPHA-3 · FASENFRAESER-BI-FACE-90°-Z:3-HM-E25-UF-+-EZI-ALPHA-3



SWISS MADE

21735A-2

Version du 07.05.2026

E2

OUTIL E2 MATÉRIAU HAUTE PRÉCISION

$\lambda = 0^\circ$   
 $Y = 8^\circ$

ANGLES OUTILS LAMBDA 0° GAMMA 8°



INTERFACE MULTI-POINTS BIFACE



FORET HÉLICOÏDAL COUPE LATÉRALE

## COMPATIBILITÉ MATIÈRE

●●● Excellent (3/3) ●●○ Bon (2/3) ●○○ Possible (1/3) ○○○ Non recommandé

MATIÈRE	SPÉCIFICATION	GRP	21735A-2
<b>Aciers alliés et non alliés</b> Aciers non alliés	Rm < 450 N/mm <sup>2</sup>	1a	●●●
	Rm 450–700 N/mm <sup>2</sup>	1b	●●●
	Rm 700–900 N/mm <sup>2</sup>	1c	●●●
	Rm > 1200 N/mm <sup>2</sup>	1d	●●●
<b>Aciers Inox</b> Aciers inoxydables	Rm < 650 N/mm <sup>2</sup>	2a	●●●
	Rm 650–950 N/mm <sup>2</sup>	2b	●●●
	Rm > 950 N/mm <sup>2</sup>	2c	●●●
<b>Aciers trempés</b> Aciers durcis	44–56 HRC	3a	●●○
	57–67 HRC	3b	●○○
<b>Matériaux exotiques</b> Alliages spéciaux	< 32 HRC	4a	●●○
	> 32 HRC	4b	●●○
<b>Graphite</b> Graphite industriel		5	●●●
<b>Fontes</b> Fonte grise / nodulaire	< 32 HRC	6a	●●●
	> 32 HRC	6b	●●●
<b>Titane</b> Alliages titane	Rm < 600 N/mm <sup>2</sup>	7a	●●●
	600 < Rm N/mm <sup>2</sup>	7b	●●●
<b>Alliages Nickel</b> Inconel, Hastelloy	Rm < 1000 N/mm <sup>2</sup>	8a	●●○
	Rm > 1000 N/mm <sup>2</sup>	8b	●●○
<b>Cuivre, laiton, bronze</b> Cuivreux	Rm < 850 N/mm <sup>2</sup>	9a	●●○
	Rm > 850 N/mm <sup>2</sup>	9b	●●○
<b>Aluminium</b> Alliages aluminium	Si < 0.5%	10a	●●○
	0.5% < Si < 5%	10b	●●○
	Si > 5%	10c	●●●
<b>Matières synthétiques</b> Plastiques techniques	Thermoplastique	11a	●○○
	Thermodurcissable	11b	●○○
<b>Matières composites</b> Composites renforcés	Fibre de verre / GFK	12a	●●●
	Fibre de carbone / KFK	12b	●●●
<b>Métaux précieux</b> Or, platine, argent	Or	13a	●●○
	Platine	13b	●●○

## DESSIN TECHNIQUE

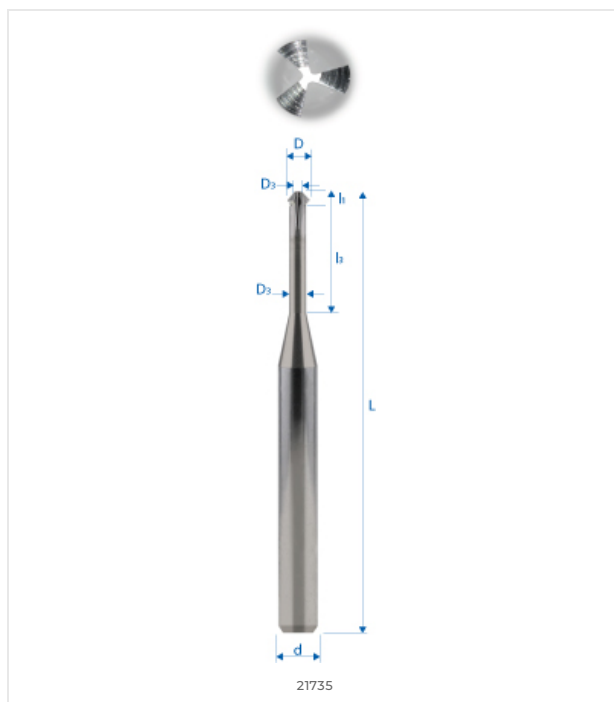

## DIMENSIONS

DIMENSIONS NOMINALES	
D (0 / -0.01)	2 mm
d (h5)	3 mm
L	50 mm
l1	0.5 mm
l3	6 mm
d3	–
R	–
e	–
Z	3
Chanfrein K	–
w° collision	3.7°



E-SHOP / EZI CUT  
[eskenazi.ch/eshop/21735A-2](https://eskenazi.ch/eshop/21735A-2)