

FRAISE-D'ÉBAUCHE-MD-E2-+-EZI-ALPHA-+L3-POUR-ACIERS · ROUGHING-ENDMILL-SC-E2-+-EZI-ALPHA-+L3-FOR-STEEL · SCHAFT-SCHRUPPFRÄSER-HM-E2-+-EZI-ALPHA-+L3-FÜR-STAHL



SWISS MADE

22134A-6 Version du 07.05.2026

E2 OUTIL E2 MATÉRIAU HAUTE PRÉCISION	$\lambda = 48^\circ$ $\gamma = 3^\circ$ ANGLES DE COUPE $\approx 48^\circ \approx 3^\circ$	0.005-0.03 45 CHANFREIN 45° TOLÉRANCE 0.005- 0.03	 FORET HÉLICOÏDAL À DOUBLE SENS	l_1 1.5xD PROFONDEUR 1.5XD OUTIL PRÉCISION	l3 OUTIL DE CONTACT TROIS POINTS	 FORETS EXTRA LONGS PRÉCISION	 ICÔNE D'ANGLES RÉGLABLES
--	---	---	--	--	--	---	------------------------------------

COMPATIBILITÉ MATIÈRE

●●● Excellent (3/3) ●●○ Bon (2/3) ●○○ Possible (1/3) ○○○ Non recommandé

MATIÈRE	SPÉCIFICATION	GRP	22134A-6
Aciers alliés et non alliés <i>Aciers non alliés</i>	Rm < 450 N/mm ²	1a	●●○
	Rm 450–700 N/mm ²	1b	●●○
	Rm 700–900 N/mm ²	1c	●●○
	Rm > 1200 N/mm ²	1d	●●○
Aciers Inox <i>Aciers inoxydables</i>	Rm < 650 N/mm ²	2a	●●○
	Rm 650–950 N/mm ²	2b	●●○
	Rm > 950 N/mm ²	2c	●●○
Aciers trempés <i>Aciers durcis</i>	44–56 HRC	3a	●●○
	57–67 HRC	3b	●○○
Matériaux exotiques <i>Alliages spéciaux</i>	< 32 HRC	4a	●●○
	> 32 HRC	4b	●●○
Graphite <i>Graphite industriel</i>		5	○○○
Fontes <i>Fonte grise / nodulaire</i>	< 32 HRC	6a	●●○
	> 32 HRC	6b	●●○
Titane <i>Alliages titane</i>	Rm < 600 N/mm ²	7a	●●○
	600 < Rm N/mm ²	7b	●●○
Alliages Nickel <i>Inconel, Hastelloy</i>	Rm < 1000 N/mm ²	8a	●●○
	Rm > 1000 N/mm ²	8b	●●○
Cuivre, laiton, bronze <i>Cuivreux</i>	Rm < 850 N/mm ²	9a	○○○
	Rm > 850 N/mm ²	9b	○○○
Aluminium <i>Alliages aluminium</i>	Si < 0.5%	10a	○○○
	0.5% < Si < 5%	10b	○○○
	Si > 5%	10c	○○○
Matières synthétiques <i>Plastiques techniques</i>	Thermoplastique	11a	○○○
	Thermodurcissable	11b	○○○
Matières composites <i>Composites renforcés</i>	Fibre de verre / GFK	12a	○○○
	Fibre de carbone / KFK	12b	○○○
Métaux précieux <i>Or, platine, argent</i>	Or	13a	○○○
	Platine	13b	●○○

DESSIN TECHNIQUE

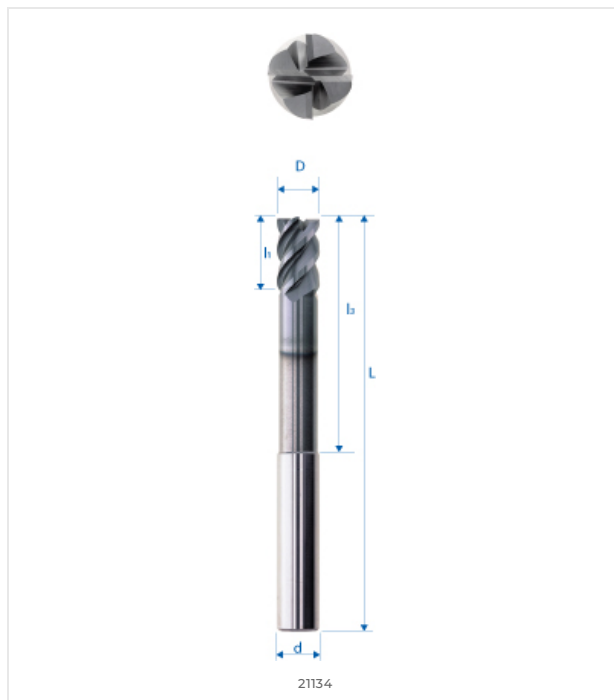

DIMENSIONS

DIMENSIONS NOMINALES	
D (0 / -0.01)	6 mm
d (h5)	6 mm
L	68 mm
l1	9 mm
l3	33 mm
d3	–
R	–
e	–
Z	3
Chanfrein K	0.1
w° collision	–



E-SHOP / EZI CUT
eskenazi.ch/eshop/22134A-6