

FRAISE-DE-FINITION-MD-E2+-EZI-DUR · FINISHING- ENDMILL-SC-E2+-EZI-DUR · SCHLICHTFRÄSER-HM-E2+- EZI-DUR



SWISS MADE

22144X-16

Version du 21.06.2026

E2

OUTIL E2 MATÉRIAU
HAUTE PRÉCISION

$\lambda = 45^\circ$
 $\gamma = 8^\circ$

ANGLES DE COUPE $\gamma 45^\circ$
 $\gamma 8^\circ$

$\phi \leq 6$ $\phi > 6$
90° 45°

CHANFREIN $\phi < 6$ $\phi > 6$
90° 45°



FORET HÉLICOÏDAL À
DOUBLE SENS

$\frac{L}{3}$
8xD

OUTIL DE COUPE 8XD
LONGUEUR L3



BARRES DE MESURE
LONGUEUR OUTILS

COMPATIBILITÉ MATIÈRE

●●● Excellent (3/3) ●●○ Bon (2/3) ●○○ Possible (1/3) ○○○ Non recommandé

MATIÈRE	SPÉCIFICATION	GRP	22144X-16
Aciers alliés et non alliés Aciers non alliés	Rm < 450 N/mm ²	1a	●●○
	Rm 450-700 N/mm ²	1b	●●○
	Rm 700-900 N/mm ²	1c	●●○
	Rm > 1200 N/mm ²	1d	●●○
Aciers Inox Aciers inoxydables	Rm < 650 N/mm ²	2a	●●○
	Rm 650-950 N/mm ²	2b	●●○
	Rm > 950 N/mm ²	2c	●●○
Aciers trempés Aciers durcis	44-56 HRC	3a	●●●
	57-67 HRC	3b	●●●
Matériaux exotiques Alliages spéciaux	< 32 HRC	4a	●●●
	> 32 HRC	4b	●●●
Graphite Graphite industriel		5	●○○
Fontes Fonte grise / nodulaire	< 32 HRC	6a	●●○
	> 32 HRC	6b	●●○
Titane Alliages titane	Rm < 600 N/mm ²	7a	●●○
	600 < Rm N/mm ²	7b	●●○
Alliages Nickel Inconel, Hastelloy	Rm < 1000 N/mm ²	8a	●●●
	Rm > 1000 N/mm ²	8b	●●●
Cuivre, laiton, bronze Cuivreux	Rm < 850 N/mm ²	9a	○○○
	Rm > 850 N/mm ²	9b	○○○
Aluminium Alliages aluminium	Si < 0.5%	10a	●○○
	0.5% < Si < 5%	10b	●○○
	Si > 5%	10c	●●○
Matières synthétiques Plastiques techniques	Thermoplastique	11a	○○○
	Thermodurcissable	11b	○○○
Matières composites Composites renforcés	Fibre de verre / GFK	12a	●○○
	Fibre de carbone / KFK	12b	●○○
Métaux précieux Or, platine, argent	Or	13a	●○○
	Platine	13b	●○○

DESSIN TECHNIQUE

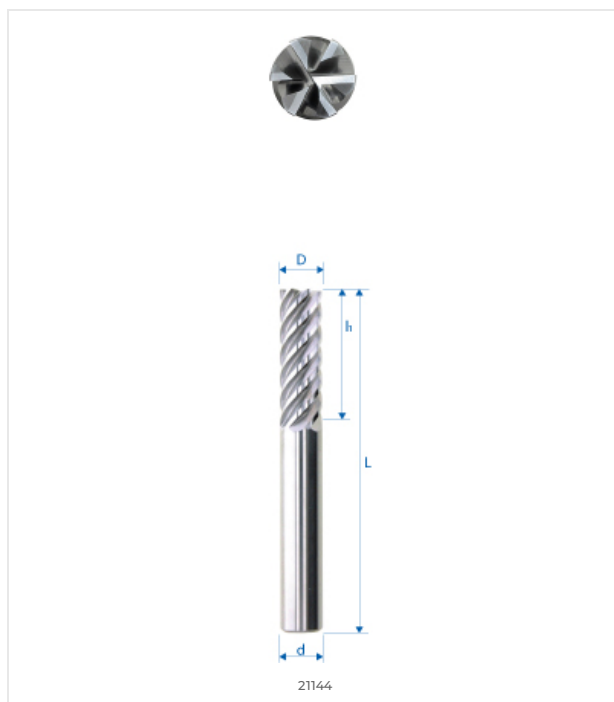

DIMENSIONS

DIMENSIONS NOMINALES	
D (0 / -0.01)	16 mm
d (h5)	16 mm
L	92 mm
l1	38 mm
l3	-
d3	-
R	-
e	-
Z	8
Chanfrein K	0.1
w° collision	-



E-SHOP / EZI CUT
eskenazi.ch/eshop/22144X-16