

FRAISE-PROFIL-ÉBAUCHE-MD-E2-+-EZI-ALPHA,- VERSION-COURTE · ROUGHIN-ENDMILL-SC-E2-+-EZI- ALPHA,-SHORT-VERSION · SCHAFT-SCHRUPPFÄSER- HM-E2-+-EZI-ALPHA,-KURTZE-VERSION



SWISS MADE

22520A-12

Version du 08.05.2026

E2

OUTIL E2 MATÉRIAU
HAUTE PRÉCISION

$\lambda = 30^\circ$
 $\gamma = 3^\circ$

ANGLES DE COUPE $\approx 30^\circ$
 $\approx 3^\circ$

45°

MESURE D'ANGLE 45°
PRÉCISION



FORET HÉLICOÏDAL À
DOUBLE SENS

h
1.5xD

PROFONDEUR 1.5xD
OUTIL PRÉCISION



BARRES LONGUEUR
COURTE USURE OUTIL

COMPATIBILITÉ MATIÈRE

●●● Excellent (3/3) ●● Bon (2/3) ●● Possible (1/3) ○○ Non recommandé

MATIÈRE	SPÉCIFICATION	GRP	22520A-12
Aciers alliés et non alliés <small>Aciers non alliés</small>	Rm < 450 N/mm ²	1a	○○○
	Rm 450-700 N/mm ²	1b	○○○
	Rm 700-900 N/mm ²	1c	○○○
	Rm > 1200 N/mm ²	1d	○○○
Aciers Inox <small>Aciers inoxydables</small>	Rm < 650 N/mm ²	2a	○○○
	Rm 650-950 N/mm ²	2b	○○○
	Rm > 950 N/mm ²	2c	○○○
Aciers trempés <small>Aciers durcis</small>	44-56 HRC	3a	○○○
	57-67 HRC	3b	○○○
Matériaux exotiques <small>Alliages spéciaux</small>	< 32 HRC	4a	○○○
	> 32 HRC	4b	○○○
Graphite <small>Graphite industriel</small>		5	○○○
Fontes <small>Fonte grise / nodulaire</small>	< 32 HRC	6a	○○○
	> 32 HRC	6b	○○○
Titane <small>Alliages titane</small>	Rm < 600 N/mm ²	7a	○○○
	600 < Rm N/mm ²	7b	○○○
Alliages Nickel <small>Inconel, Hastelloy</small>	Rm < 1000 N/mm ²	8a	○○○
	Rm > 1000 N/mm ²	8b	○○○
Cuivre, laiton, bronze <small>Cuivreux</small>	Rm < 850 N/mm ²	9a	○○○
	Rm > 850 N/mm ²	9b	○○○
Aluminium <small>Alliages aluminium</small>	Si < 0.5%	10a	○○○
	0.5% < Si < 5%	10b	○○○
	Si > 5%	10c	○○○
Matières synthétiques <small>Plastiques techniques</small>	Thermoplastique	11a	○○○
	Thermodurcissable	11b	○○○
Matières composites <small>Composites renforcés</small>	Fibre de verre / GFK	12a	○○○
	Fibre de carbone / KFK	12b	○○○
Métaux précieux <small>Or, platine, argent</small>	Or	13a	○○○
	Platine	13b	○○○

DESSIN TECHNIQUE

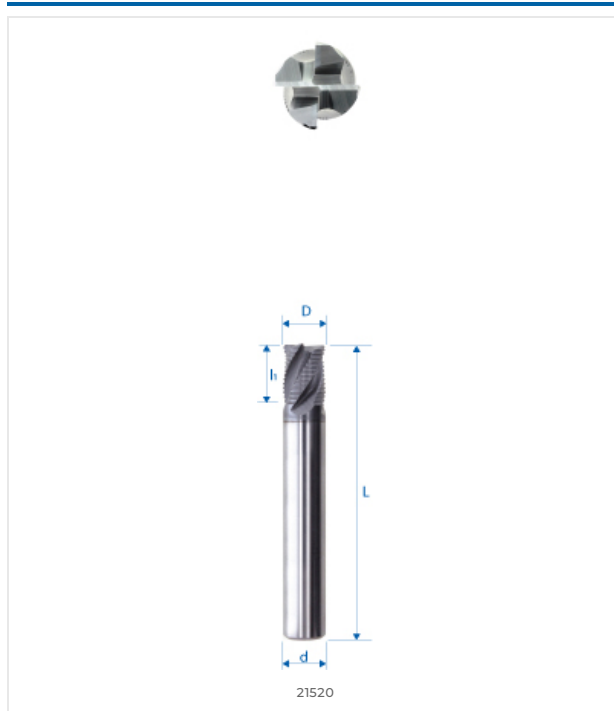

DIMENSIONS

DIMENSIONS NOMINALES	
D (0 / -0.01)	12 mm
d (h5)	12 mm
L	73 mm
h	12 mm
h3	-
d3	-
R	-
e	-
Z	4
Chanfrein K	0.4
w° collision	-



E-SHOP / EZI CUT
eskenazi.ch/eshop/22520A-12