

# FRAISE-PROFIL-ÉBAUCHE-MD-E2-+-EZI-ALPHA,- VERSION-COURTE · ROUGHIN-ENDMILL-SC-E2-+-EZI- ALPHA,-SHORT-VERSION · SCHAFT-SCHRUPPFÄSER- HM-E2-+-EZI-ALPHA,-KURTZE-VERSION



SWISS MADE

22520A-2.5-6

Version du 08.05.2026

E2

OUTIL E2 MATÉRIAU  
HAUTE PRÉCISION

$\lambda = 30^\circ$   
 $\gamma = 3^\circ$

ANGLES DE COUPE  $\gamma 30^\circ$   
 $\gamma 3^\circ$

45°

MESURE D'ANGLE 45°  
PRÉCISION



FORET HÉLICOÏDAL À  
DOUBLE SENS

h  
1.5xD

PROFONDEUR 1.5XD  
OUTIL PRÉCISION



BARRES LONGUEUR  
COURTE USURE OUTIL

## COMPATIBILITÉ MATIÈRE

●●● Excellent (3/3) ●●○ Bon (2/3) ●○○ Possible (1/3) ○○○ Non recommandé

MATIÈRE	SPÉCIFICATION	GRP	22520A-2.5-6
<b>Aciers alliés et non alliés</b> <small>Aciers non alliés</small>	Rm < 450 N/mm <sup>2</sup>	1a	●●○
	Rm 450–700 N/mm <sup>2</sup>	1b	●●○
	Rm 700–900 N/mm <sup>2</sup>	1c	●●○
	Rm > 1200 N/mm <sup>2</sup>	1d	●○○
<b>Aciers Inox</b> <small>Aciers inoxydables</small>	Rm < 650 N/mm <sup>2</sup>	2a	●●○
	Rm 650–950 N/mm <sup>2</sup>	2b	●●○
	Rm > 950 N/mm <sup>2</sup>	2c	●●○
<b>Aciers trempés</b> <small>Aciers durcis</small>	44–56 HRC	3a	○○○
	57–67 HRC	3b	○○○
<b>Matériaux exotiques</b> <small>Alliages spéciaux</small>	< 32 HRC	4a	●○○
	> 32 HRC	4b	●○○
<b>Graphite</b> <small>Graphite industriel</small>		5	○○○
<b>Fontes</b> <small>Fonte grise / nodulaire</small>	< 32 HRC	6a	●●●
	> 32 HRC	6b	●●●
<b>Titane</b> <small>Alliages titane</small>	Rm < 600 N/mm <sup>2</sup>	7a	●●○
	600 < Rm N/mm <sup>2</sup>	7b	●○○
<b>Alliages Nickel</b> <small>Inconel, Hastelloy</small>	Rm < 1000 N/mm <sup>2</sup>	8a	●○○
	Rm > 1000 N/mm <sup>2</sup>	8b	●○○
<b>Cuivre, laiton, bronze</b> <small>Cuivreux</small>	Rm < 850 N/mm <sup>2</sup>	9a	●●○
	Rm > 850 N/mm <sup>2</sup>	9b	●●○
<b>Aluminium</b> <small>Alliages aluminium</small>	Si < 0.5%	10a	○○○
	0.5% < Si < 5%	10b	○○○
	Si > 5%	10c	○○○
<b>Matières synthétiques</b> <small>Plastiques techniques</small>	Thermoplastique	11a	○○○
	Thermodurcissable	11b	○○○
<b>Matières composites</b> <small>Composites renforcés</small>	Fibre de verre / GFK	12a	○○○
	Fibre de carbone / KFK	12b	○○○
<b>Métaux précieux</b> <small>Or, platine, argent</small>	Or	13a	●●○
	Platine	13b	●○○

## DESSIN TECHNIQUE

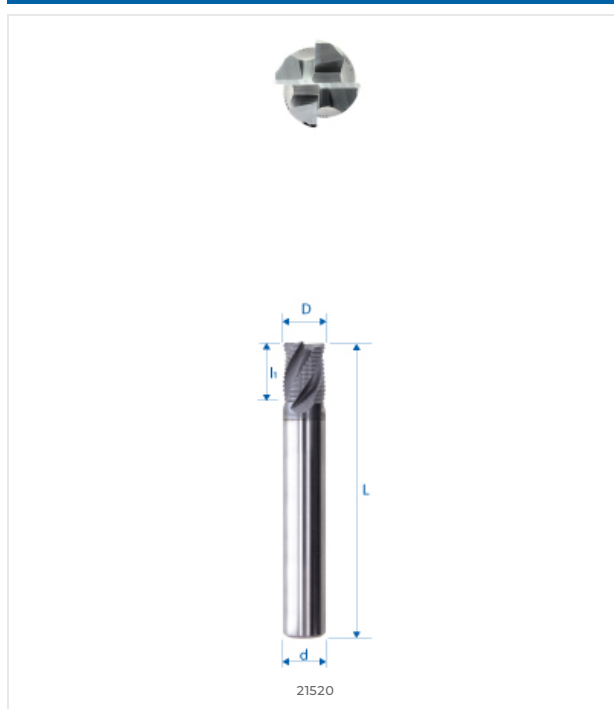

## DIMENSIONS

DIMENSIONS NOMINALES	
D (0 / -0.01)	2.5 mm
d (h5)	6 mm
L	50 mm
l1	4 mm
l3	–
d3	–
R	–
e	–
Z	3
Chanfrein K	0.2
w° collision	8.9°



E-SHOP / EZI CUT  
[eskenazi.ch/eshop/22520A-2.5-6](https://eskenazi.ch/eshop/22520A-2.5-6)

© 2026 Eskenazi SA — Carouge, Genève  
Tous droits réservés