

# FRAISE-D'ÉBAUCHE-À-PROFIL-PLAT-MD-E2+-EZI- ALPHA+L3 · ROUGHING-ENDMILL-FINE-PROFILE-SC-E2- +-EZI-ALPHA · SCHAFT-SCHRUPPFRÄSER-FEIN-PROFIL- HM-E25UF+-EZI-ALPHA



SWISS MADE

22525A-10

Version du 07.05.2026

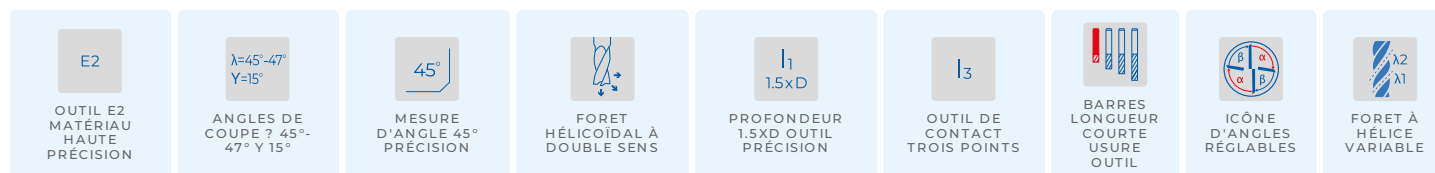

## COMPATIBILITÉ MATIÈRE

●●● Excellent (3/3) ●● Bon (2/3) ●○ Possible (1/3) ○○ Non recommandé

MATIÈRE	SPÉCIFICATION	GRP	22525A-10
<b>Aciers alliés et non alliés</b> <i>Aciers non alliés</i>	Rm < 450 N/mm <sup>2</sup>	1a	●●●
	Rm 450–700 N/mm <sup>2</sup>	1b	●●●
	Rm 700–900 N/mm <sup>2</sup>	1c	●●●
	Rm > 1200 N/mm <sup>2</sup>	1d	●○
<b>Aciers Inox</b> <i>Aciers inoxydables</i>	Rm < 650 N/mm <sup>2</sup>	2a	●●●
	Rm 650–950 N/mm <sup>2</sup>	2b	●●●
	Rm > 950 N/mm <sup>2</sup>	2c	●●●
<b>Aciers trempés</b> <i>Aciers durcis</i>	44–56 HRC	3a	○○
	57–67 HRC	3b	○○
<b>Matériaux exotiques</b> <i>Alliages spéciaux</i>	< 32 HRC	4a	●○
	> 32 HRC	4b	●○
<b>Graphite</b> <i>Graphite industriel</i>		5	○○
<b>Fontes</b> <i>Fonte grise / nodulaire</i>	< 32 HRC	6a	●●●
	> 32 HRC	6b	●●●
<b>Titane</b> <i>Alliages titane</i>	Rm < 600 N/mm <sup>2</sup>	7a	●●●
	600 < Rm N/mm <sup>2</sup>	7b	●●●
<b>Alliages Nickel</b> <i>Inconel, Hastelloy</i>	Rm < 1000 N/mm <sup>2</sup>	8a	●○
	Rm > 1000 N/mm <sup>2</sup>	8b	●○
<b>Cuivre, laiton, bronze</b> <i>Cuivreux</i>	Rm < 850 N/mm <sup>2</sup>	9a	●●●
	Rm > 850 N/mm <sup>2</sup>	9b	●●●
<b>Aluminium</b> <i>Alliages aluminium</i>	Si < 0.5%	10a	○○
	0.5% < Si < 5%	10b	○○
	Si > 5%	10c	○○
<b>Matières synthétiques</b> <i>Plastiques techniques</i>	Thermoplastique	11a	○○
	Thermodurcissable	11b	○○
<b>Matières composites</b> <i>Composites renforcés</i>	Fibre de verre / GFK	12a	○○
	Fibre de carbone / KFK	12b	○○
<b>Métaux précieux</b> <i>Or, platine, argent</i>	Or	13a	●●●
	Platine	13b	●●○

## DESSIN TECHNIQUE

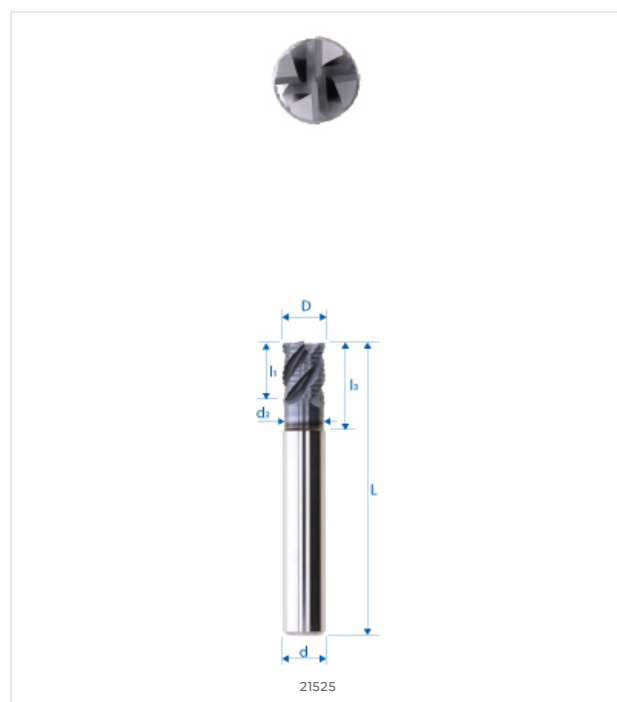

## DIMENSIONS

DIMENSIONS NOMINALES	
D (0 / -0.01)	10 mm
d (h5)	10 mm
L	66 mm
l1	12 mm
l3	20 mm
d3	–
R	–
e	–
Z	4
Chanfrein K	0.4
w° collision	–



E-SHOP / EZI CUT  
[eskenazi.ch/eshop/22525A-10](https://eskenazi.ch/eshop/22525A-10)